



SG&P

Scientific Glass & Plastic

Serving the Chemical Industry



Hello,

I am delighted to introduce you to S. G. & P., Inc. This company is a family owned corporation founded in 1968 by my father, Rex Epps. Upon retiring as a scientific glassblower, he began supplying fabricated plastic and scientific glass products to the local petrochemical industry in Brazoria County, Texas. His goal, then, and my goal, now, remain the same: Supply quality products and keep the customers satisfied.

We are a continually growing company with enthusiastic employees who are dedicated to fulfilling customer needs. Individual attention is given to all jobs, whether large or small.

At S. G. & P., we fabricate custom thermoplastic and scientific glassware products. We have a diverse customer base including the chemical, petrochemical, environmental, petroleum, transportation, research, education, medical and recreation industries. Today we supply customers throughout the United States and abroad.

If plastics or glassware can fill the need, then we can do the job.

Sincerely,

Joe Epps
Owner



General Contents

	Page Number
Ordering Information	2
Thermoplastics	3 - 7
Tower Internals	8 - 9
Vacuum Forming	10
Flange Spacers	11 - 31
Material Properties	32 - 44
Glassware	45 - 126



Scientific Glass & Plastic

Ordering Information

Call toll free

1-800-880-7722

or

Ph: 979-233-7491

Fx: 979-233-0371

For your convenience, we accept
Visa, Mastercard and American Express



S. G. & P., Inc.

P. O. Box 2518

Freeport, Texas 77542

1022 N. Avenue G

Freeport, Texas 77541

Visit Us On-line

www.sg-p.com

email: info@sg-p.com

Ph: 979-233-7491

Ph: 800-880-7722

Fx: 979-233-0371

We are distributors for the following manufacturers:

Eslon Thermoplastics

PVC / CPVC pipe & fittings

Spears Manufacturing

PVC / CPVC fittings

Compression Polymers Group

**HDPE, Polypropylene, HYLAR® PVDF, and
CPG Seaboard™ sheet**

Vycom

PVC and CPVC sheet

Westlake Plastics Company

Kynar® PVDF sheet

Trademarks

Corzan™ CPVC is a trademark of the B.F. Goodrich Company

CPG Seaboard™ is a trademark of the Compression Polymers Group

HYLAR® is a registered trademark of Ausimont U.S.A.

Kynar® is a registered trademark of Elf Atochem North America

Lexan® is a registered trademark of GE Plastics

Lucite® is a registered trademark of ICI Acrylics

Plexiglas® is a registered trademark of the Rohm & Haas Co.

Pyrex® is a registered trademark of the Corning Corporation

Teflon® is a registered trademark of E. I. DuPont & Co.

Material Safety Data Sheets are available upon request on any thermoplastic or glass that we carry.

Acrylic

Recognized under the brand names of Plexiglas® and Lucite®, acrylic is an optically clear, transparent material having outstanding weatherability, high impact resistance, good chemical resistance and is easily thermoformed and fabricated.

Acrylic is less than half the weight of glass and is suitable in a wide range of applications. Some of the most requested items that we routinely fabricate out of acrylic include: fume hoods, dry boxes, draft shields, instrument covers and enclosures, safety shields, battery covers, flanged spools, transparent tanks and sight glasses.



24" diameter acrylic tank, with PVC stand



12" diameter acrylic flanged column with PVC flanged connections



Assorted acrylic flanged spools

Polycarbonate

Lexan® polycarbonate sheet is virtually unbreakable transparent plastic, excellent in applications where safety and security are important. Polycarbonate can be used in many of the same applications as acrylic when impact strength is a factor.



Large acrylic tank with metal support frame



Smoked acrylic instrument enclosure with glove ports

PVC (Polyvinyl Chloride)

PVC sheet is a normal impact, high corrosion resistant material, ideally suited where chemical resistance is necessary. It's high strength-to-weight ratio, cost efficiency, ease of fabrication and eco-balance make it an excellent choice. PVC is easily machined and weldable. We routinely use PVC sheet to fabricate various types of enclosures and covers, cabinets, fume hoods and tanks, and in conjunction with PVC pipe and fittings.

PVC pipe and fittings give excellent, maintenance free performance over long periods of time and have outstanding chemical resistance to nearly all acids, alkalis, alcohols, halogens and many other corrosive materials. It is weather resistant and non-toxic.



Acrylic spools with custom fabricated PVC flanges



PVC vat with sliding covers in a metal frame

Corzan™ CPVC (Chlorinated Polyvinyl Chloride)

Corzan™ CPVC sheet is a high heat, corrosion resistant material with properties similar to PVC, but because of its excellent corrosion resistance at elevated temperatures, it is ideally suited for self-supporting constructions where high temperatures are a concern.

We have extensive experience with CPVC as a construction material, including tower internals and many other process applications.



Motionless mixing pipe insert fabricated from CPVC sheet



PVC cabinets

Corzan™ CPVC pipe and fittings gain advantage over PVC by retaining its mechanical strength at high temperatures.



Acrylic glove box with transfer chamber

HDPE (High Density Polyethylene)

HDPE is an economical, high impact, lightweight thermoplastic which characteristics include excellent chemical resistance, high tensile strength, resilience, stress crack and abrasion resistance. It is easily machined and requires welded or mechanical style of construction.

We use HDPE to fabricate many items for the laboratory and plant processes, including tanks, countertops, catch pans, fume hoods and lab ware carriers. It meets FDA and USDA requirements.



HDPE lab countertop with removable sinks



Radial liquid distribution unit fabricated from polypropylene sheet, CPVC pipe and fittings and enclosed in a custom fitted stand fabricated from polyethylene pipe and sheet

UHMWPE (Ultra High Molecular Weight Polyethylene)

UHMWPE has extremely high abrasion resistance when compared to other thermoplastics. It also has exceptional impact resistance, even at cryogenic temperatures, is chemical resistant and is self-lubricating. It also meets FDA and USDA requirements.



Polyethylene rotary trickle distributor, used in a bio-pond application as an alternate to the aluminum one which had failed in service



HDPE tank with spigot and polypropylene strainer basket

Some common applications for UHMWPE are chutes, conveyors, wear plates, bushings and rollers.

Porous HDPE

Porous HDPE is a free-sintered material that produces porous plastic products with excellent filtration efficiency of fine solid particulate combined with excellent flowability of liquids and gases. Controlled particle size distribution and a precise temperature cycle are used to produce a wide range of interconnected cell structures and specific pore size ranges. These pore structures are designed and controlled to function in a variety of applications such as filtering, wicking, diffusing or venting gases, and sound muffling.

Porous plastics retain most of the physical properties of their solid counterparts, but also offer a unique set of properties. The unique "tortuous filtration path" of the material produces high filtration efficiency combining the properties of both surface and depth filters. Porous plastics have excellent resiliency, high physical strength and light weight providing a rugged, easily handled part. Filtration efficiencies of 99.8% can be achieved.



Porous HDPE filter element fabricated from porous HDPE tube and HDPE rod for the threaded end and end caps, using butt fusion technique



Porous HDPE filter plate, ten feet long with solid HDPE sheet welded on as a frame with o-ring grooves routed on the face of the frame



CPG Seaboard™

We can fabricate filtration products from porous HDPE sheet and tube to your specifications.

CPG Seaboard™

CPG Seaboard™ is a marine grade high density polyethylene sheet manufactured from the highest density HDPE resin, ensuring that it will be the most rigid and dimensionally stable product available. Pre-production treatment provides every sheet with enhanced ability to resist the harmful effects of salt water, moisture and direct sunlight (UV degradation). It has a slight textured surface which minimizes the appearance of scratches.

Call **1-800-880-7722** Toll Free

CPG Seaboard™ is fabricated and welded using the same techniques as used with HDPE. It also meets all regulations of the FDA.

Polypropylene

Polypropylene is an economical, light-weight thermoplastic that offers high corrosion resistance, abrasion and impact resistance. It exhibits tensile strength and stiffness at elevated temperatures superior to HDPE. Polypropylene carries USDA and FDA approval and is stain resistant. It is machined easily and requires welded or mechanical style of construction.



Countertop for cabinet on a bar-b-que pit trailer, fabricated from CPG Seaboard™

We utilize polypropylene in the fabrication of flange spacers, catch pans, countertops and various other applications.

TEFLON® PTFE (Polytetrafluoroethylene)

Teflon® is used to produce products which have service temperature capabilities exceeding all other thermoplastics. It has a combination of chemical, electrical, mechanical and thermal properties unmatched by any other material, and it is the most chemically inert of any material known. Almost nothing sticks to Teflon® and it is the most heat resistant of organic materials. It is unaffected by weathering and is an excellent electrical insulator.

We use Teflon® to fabricate flange spacers, gaskets and numerous machined parts.

PVDF (Polyvinylidene Fluoride)

PVDF, known under the brand names of Kynar® and Hylar®, is a high performance thermoplastic that combines great mechanical strength and high abrasion resistance with a broad temperature range. It is highly resistant to most environmental conditions and corrosive chemicals.

We routinely use PVDF in the fabrication of flange spacers, tower internals and wherever superior thermoplastic characteristics are necessary.



Corzan™ CPVC weir trough distributor with elevated parting box, utilizing triangular weirs for flow distribution. Good for fouling services and turndown capabilities.



Corzan™ CPVC chimney tray for liquid collection and draw-off. Contains multiple vapor risers for equal vapor distribution.



PVDF liquid redistributor with vapor risers and angled drip tubes. Sectional construction incorporates lateral cross flow tubes for liquid transfer.



MTS-109 PVC distributor, fabricated under exclusive license with Nutter Engineering from Dow Chemical. Sectional design minimizes out of level effects. Angle drop tubes provide flexibility in turndown situation.



PVDF eight-foot diameter, liquid distributor designed to rest between tower body flanges. Distributor is fabricated with slotted weir down pipes and wipe vapor passages near the flanges.



PVDF gas injection type packing support, spanning eight feet in diameter. High open area design, while not compromising its rigidity.



PVDF pipe-arm (ladder-arm) type distributor. This type distributor can be fabricated for use in liquid or vapor applications. It can also be fabricated with fitted spray nozzles.



PVDF eight-foot diameter, single vapor riser liquid collector, with welded PVC wall wiper for total liquid drain-off. Designed for critical service requiring zero liquid leakage. Collector was piece welded inside the tower using S.G. & P. field services.



PVDF 84" diameter, gas injection packing support plate with high open area. Support plate utilizes 2" PVDF pipe with encapsulate FRP rod for added rigidity.



PVDF three-foot diameter, gas injection type packing support designed to fit between tower body flanges and also designed for a high open area.

Vacuum formed domes for bus shelters fabricated from high impact acrylic.



CVPC liner vacuum formed in two halves incorporating ribs in the mold for rigidity. The pieces are then welded together and overlaid in fiberglass.

GENERAL INFORMATION

- ❖ Material selection in this catalog is consistent with that of plastic lined pipe. Other materials available.
- ❖ All materials listed are in stock in thicknesses ranging from 1/2" thru 2". Other thicknesses available.
- ❖ All PVDF and PP spacers are stamped as such for ease for identification.
- ❖ All dimensional information in this catalog is based on standards.
- ❖ Any spacer can be customized to your specifications.

Table of Contents	
Thermoplastic Flange Spacers	
	Page Number
Dimensional Information	12-15
Blind Ring	16-17
Standard Ring	18-19
Blind Full Face	20-21
Standard Full Face	22-23
Tapered Bore Ring	24-25
Orifice Ring	26-27
Tapered Bore Full Face	28-29
Orifice Full Face	30-31



ORDER SPACERS BY PART NUMBER OR DESCRIPTION.

We offer custom spacers at competitive prices and prompt service.

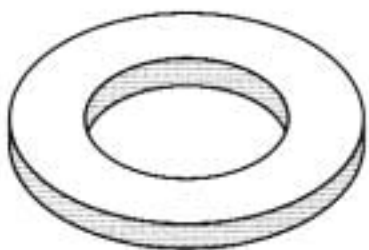

Standard Ring Spacer

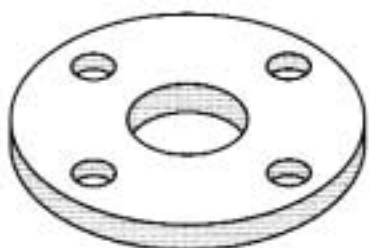
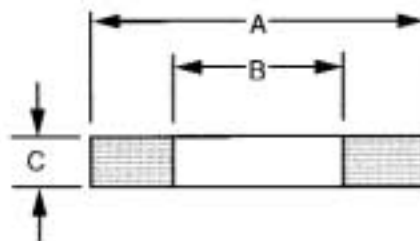

Standard Full Face Spacer

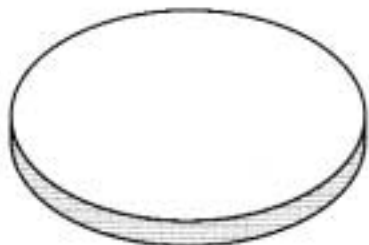
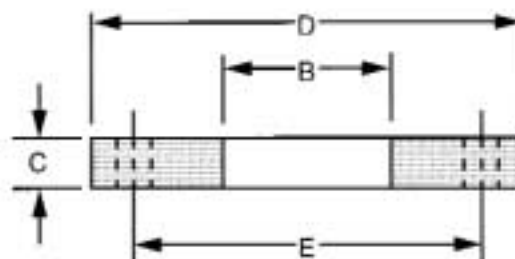

Blind Ring Spacer

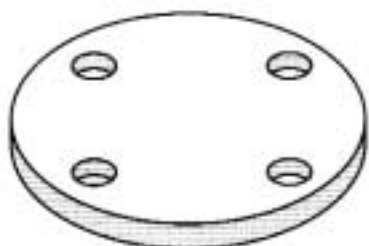
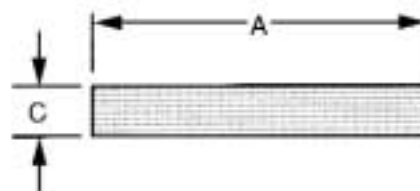

Blind Full Face Spacer

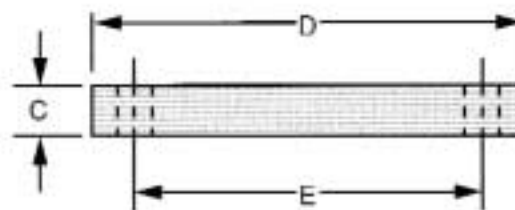

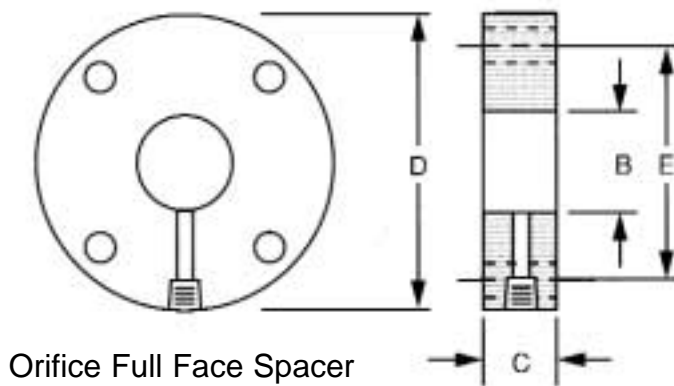
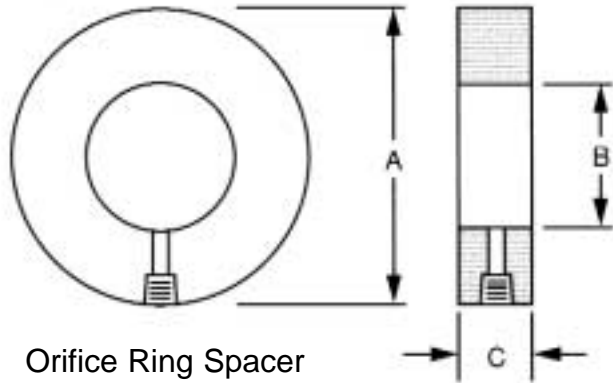

Tap Information for Orifice Spacers

Tap Size	Min. Dimension C
1/4	1
3/8	1 1/8
1/2	1 1/4
3/4	1 1/2
1	1 3/4
1 1/4	2 1/4
1 1/2	2 1/2

Dimensional Information for Class 125 and 150 Spacers

Ring and full face spacers (standard, blind and orifice)

Size	Ring A	B		Full Face D	Bolt Holes		Bolt Circle E
		PP PVDF	PTFE		No.	Size	
1	2 5/8	11/16	25/32	4 1/4	4	5/8	3 1/8
1 1/2	3 3/8	1 5/16	1 5/16	5	4	5/8	3 7/8
2	4 1/8	1 3/4	1 3/4	6	4	3/4	4 3/4
2 1/2	4 7/8	2 3/32	-	7	4	3/4	5 1/2
3	5 3/8	2 11/16	2 23/32	7 1/2	4	3/4	6
4	6 7/8	3 5/8	3 11/16	9	8	3/4	7 1/2
6	8 3/4	5 9/16	5 23/32	11	8	7/8	9 1/2
8	11	7 1/2	7 5/8	13 1/2	8	7/8	11 3/4
10	13 3/8	9 11/16	10	16	12	1	14 1/4
12	16 1/8	12	12	19	12	1	17

Note: "C" dimension -- thickness to be specified.

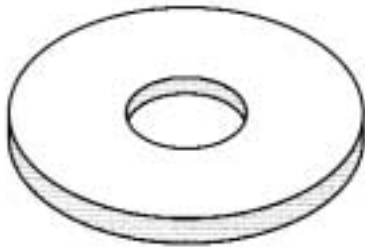

Reducing Ring Spacer

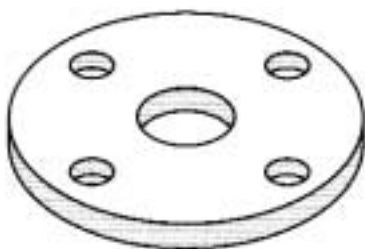
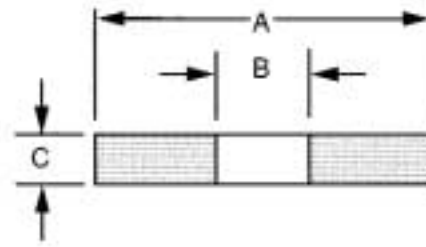

Reducing Full Face Spacer

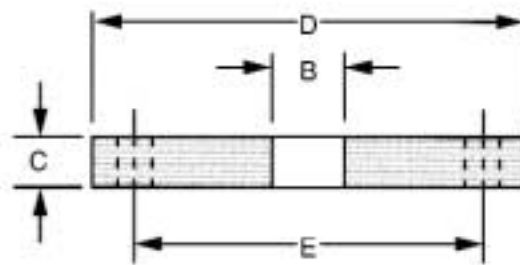

Dimensional Information for Class 125 and 150 Reducing Spacers

Ring and full face spacers

Size	A	B		Full Face D	Bolt Holes		Bolt Circle E
		PP PVDF	PTFE		No.	Size	
1 1/2 x 1	3 3/8	11/16	25/32	5	4	5/8	3 7/8
2 x 1	4 1/8	11/16	25/32	6	4	3/4	4 3/4
2 x 1 1/2	4 1/8	1 5/16	1 5/16	6	4	3/4	4 3/4
2 1/2 x 1 1/2	4 7/8	1 5/16	1 5/16	7	4	3/4	5 1/2
2 1/2 x 2	4 7/8	1 3/4	1 3/4	7	4	3/4	5 1/2
3 x 2	5 3/8	1 3/4	1 3/4	7 1/2	4	3/4	6
3 x 2 1/2	5 3/8	2 3/32	-	7 1/2	4	3/4	6
4 x 2 1/2	6 7/8	2 3/32	-	9	8	3/4	7 1/2
4 x 3	6 7/8	2 11/16	2 23/32	9	8	3/4	7 1/2
6 x 4	8 3/4	3 5/8	3 11/16	11	8	7/8	9 1/2
8 x 6	11	5 9/16	5 23/32	13 1/2	8	7/8	11 3/4

Note: "C" dimension -- thickness to be specified. (1/2" is typical)

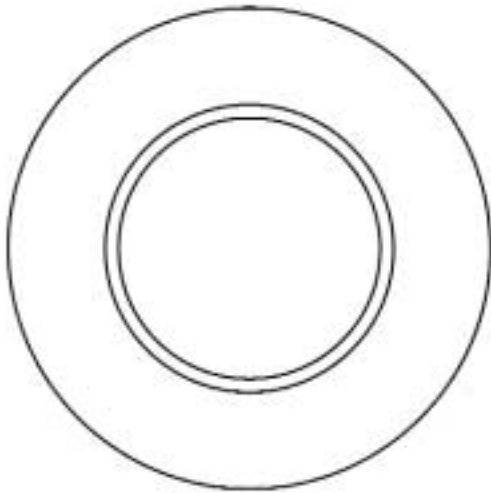

Tapered Bore Ring Spacer

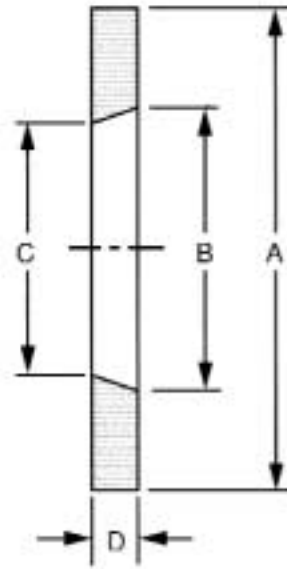

Dimensional Information for Tapered Bore Ring Spacers

Size	A	B	C	D
1	2.63	1.06	1.06	.50
1 1/2	3.38	1.63	1.31	.50
2	4.13	2.25	1.75	.50
3	5.38	3.00	2.69	.50
4	6.88	4.00	3.62	.50
6	8.75	6.00	5.56	1.00
8	11.00	8.25	7.62	1.00
10	13.38	10.00	9.56	1.25
12	16.12	11.62	11.62	1.25

Full face tapered bore spacers (not shown) also available.

Note: Tapered bore spacers are beveled for use with a butterfly valve.

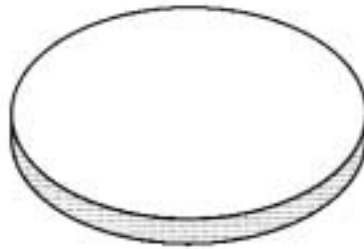

POLYPROPYLENE						
Size	Thickness					
	1/2"	3/4"	1"	1 1/4"	1 1/2"	2"
1"	# 1111	# 1112	# 1113	# 1114	# 1115	# 1116
1 1/2"	# 1121	# 1122	# 1123	# 1124	# 1125	# 1126
2"	# 1131	# 1132	# 1133	# 1134	# 1135	# 1136
3"	# 1141	# 1142	# 1143	# 1144	# 1145	# 1146
4"	# 1151	# 1152	# 1153	# 1154	# 1155	# 1156
6"	# 1161	# 1162	# 1163	# 1164	# 1165	# 1166
8"	# 1171	# 1172	# 1173	# 1174	# 1175	# 1176
10"	# 1181	# 1182	# 1183	# 1184	# 1185	# 1186
12"	# 1191	# 1192	# 1193	# 1194	# 1195	# 1196

PVDF (KYNAR®)						
Size	Thickness					
	1/2"	3/4"	1"	1 1/4"	1 1/2"	2"
1"	# 1211	# 1212	# 1213	# 1214	# 1215	# 1216
1 1/2"	# 1221	# 1222	# 1223	# 1224	# 1225	# 1226
2"	# 1231	# 1232	# 1233	# 1234	# 1235	# 1236
3"	# 1241	# 1242	# 1243	# 1244	# 1245	# 1246
4"	# 1251	# 1252	# 1253	# 1254	# 1255	# 1256
6"	# 1261	# 1262	# 1263	# 1264	# 1265	# 1266
8"	# 1271	# 1272	# 1273	# 1274	# 1275	# 1276
10"	# 1281	# 1282	# 1283	# 1284	# 1285	# 1286
12"	# 1291	# 1292	# 1293	# 1294	# 1295	# 1296

TEFLON®						
Size	Thickness					
	1/2"	3/4"	1"	1 1/4"	1 1/2"	2"
1"	# 1311	# 1312	# 1313	# 1314	# 1315	# 1316
1 1/2"	# 1321	# 1322	# 1323	# 1324	# 1325	# 1326
2"	# 1331	# 1332	# 1333	# 1334	# 1335	# 1336
3"	# 1341	# 1342	# 1343	# 1344	# 1345	# 1346
4"	# 1351	# 1352	# 1353	# 1354	# 1355	# 1356
6"	# 1361	# 1362	# 1363	# 1364	# 1365	# 1366
8"	# 1371	# 1372	# 1373	# 1374	# 1375	# 1376
10"	# 1381	# 1382	# 1383	# 1384	# 1385	# 1386
12"	# 1391	# 1392	# 1393	# 1394	# 1395	# 1396

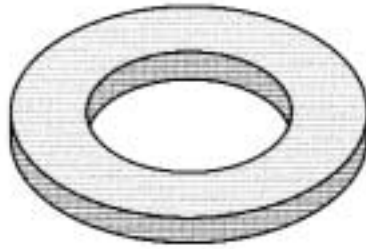

POLYPROPYLENE						
Size	Thickness					
	1/2"	3/4"	1"	1 1/4"	1 1/2"	2"
1"	# 2111	# 2112	# 2113	# 2114	# 2115	# 2116
1 1/2"	# 2121	# 2122	# 2123	# 2124	# 2125	# 2126
2"	# 2131	# 2132	# 2133	# 2134	# 2135	# 2136
3"	# 2141	# 2142	# 2143	# 2144	# 2145	# 2146
4"	# 2151	# 2152	# 2153	# 2154	# 2155	# 2156
6"	# 2161	# 2162	# 2163	# 2164	# 2165	# 2166
8"	# 2171	# 2172	# 2173	# 2174	# 2175	# 2176
10"	# 2181	# 2182	# 2183	# 2184	# 2185	# 2186
12"	# 2191	# 2192	# 2193	# 2194	# 2195	# 2196

PVDF (KYNAR®)						
Size	Thickness					
	1/2"	3/4"	1"	1 1/4"	1 1/2"	2"
1"	# 2211	# 2212	# 2213	# 2214	# 2215	# 2216
1 1/2"	# 2221	# 2222	# 2223	# 2224	# 2225	# 2226
2"	# 2231	# 2232	# 2233	# 2234	# 2235	# 2236
3"	# 2241	# 2242	# 2243	# 2244	# 2245	# 2246
4"	# 2251	# 2252	# 2253	# 2254	# 2255	# 2256
6"	# 2261	# 2262	# 2263	# 2264	# 2265	# 2266
8"	# 2271	# 2272	# 2273	# 2274	# 2275	# 2276
10"	# 2281	# 2282	# 2283	# 2284	# 2285	# 2286
12"	# 2291	# 2292	# 2293	# 2294	# 2295	# 2296

TEFLON®						
Size	Thickness					
	1/2"	3/4"	1"	1 1/4"	1 1/2"	2"
1"	# 2311	# 2312	# 2313	# 2314	# 2315	# 2316
1 1/2"	# 2321	# 2322	# 2323	# 2324	# 2325	# 2326
2"	# 2331	# 2332	# 2333	# 2334	# 2335	# 2336
3"	# 2341	# 2342	# 2343	# 2344	# 2345	# 2346
4"	# 2351	# 2352	# 2353	# 2354	# 2355	# 2356
6"	# 2361	# 2362	# 2363	# 2364	# 2365	# 2366
8"	# 2371	# 2372	# 2373	# 2374	# 2375	# 2376
10"	# 2381	# 2382	# 2383	# 2384	# 2385	# 2386
12"	# 2391	# 2392	# 2393	# 2394	# 2395	# 2396

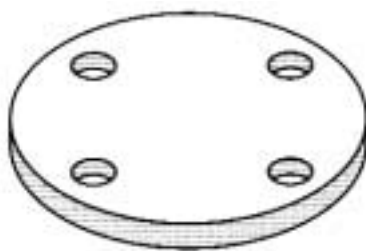

POLYPROPYLENE						
Size	Thickness					
	1/2"	3/4"	1"	1 1/4"	1 1/2"	2"
1"	# 3111	# 3112	# 3113	# 3114	# 3115	# 3116
1 1/2"	# 3121	# 3122	# 3123	# 3124	# 3125	# 3126
2"	# 3131	# 3132	# 3133	# 3134	# 3135	# 3136
3"	# 3141	# 3142	# 3143	# 3144	# 3145	# 3146
4"	# 3151	# 3152	# 3153	# 3154	# 3155	# 3156
6"	# 3161	# 3162	# 3163	# 3164	# 3165	# 3166
8"	# 3171	# 3172	# 3173	# 3174	# 3175	# 3176
10"	# 3181	# 3182	# 3183	# 3184	# 3185	# 3186
12"	# 3191	# 3192	# 3193	# 3194	# 3195	# 3196

PVDF (KYNAR®)						
Size	Thickness					
	1/2"	3/4"	1"	1 1/4"	1 1/2"	2"
1"	# 3211	# 3212	# 3213	# 3214	# 3215	# 3216
1 1/2"	# 3221	# 3222	# 3223	# 3224	# 3225	# 3226
2"	# 3231	# 3232	# 3233	# 3234	# 3235	# 3236
3"	# 3241	# 3242	# 3243	# 3244	# 3245	# 3246
4"	# 3251	# 3252	# 3253	# 3254	# 3255	# 3256
6"	# 3261	# 3262	# 3263	# 3264	# 3265	# 3266
8"	# 3271	# 3272	# 3273	# 3274	# 3275	# 3276
10"	# 3281	# 3282	# 3283	# 3284	# 3285	# 3286
12"	# 3291	# 3292	# 3293	# 3294	# 3295	# 3296

TEFLON®						
Size	Thickness					
	1/2"	3/4"	1"	1 1/4"	1 1/2"	2"
1"	# 3311	# 3312	# 3313	# 3314	# 3315	# 3316
1 1/2"	# 3321	# 3322	# 3323	# 3324	# 3325	# 3326
2"	# 3331	# 3332	# 3333	# 3334	# 3335	# 3336
3"	# 3341	# 3342	# 3343	# 3344	# 3345	# 3346
4"	# 3351	# 3352	# 3353	# 3354	# 3355	# 3356
6"	# 3361	# 3362	# 3363	# 3364	# 3365	# 3366
8"	# 3371	# 3372	# 3373	# 3374	# 3375	# 3376
10"	# 3381	# 3382	# 3383	# 3384	# 3385	# 3386
12"	# 3391	# 3392	# 3393	# 3394	# 3395	# 3396

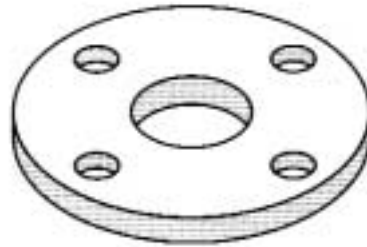

POLYPROPYLENE						
Size	Thickness					
	1/2"	3/4"	1"	1 1/4"	1 1/2"	2"
1"	# 4111	# 4112	# 4113	# 4114	# 4115	# 4116
1 1/2"	# 4121	# 4122	# 4123	# 4124	# 4125	# 4126
2"	# 4131	# 4132	# 4133	# 4134	# 4135	# 4136
3"	# 4141	# 4142	# 4143	# 4144	# 4145	# 4146
4"	# 4151	# 4152	# 4153	# 4154	# 4155	# 4156
6"	# 4161	# 4162	# 4163	# 4164	# 4165	# 4166
8"	# 4171	# 4172	# 4173	# 4174	# 4175	# 4176
10"	# 4181	# 4182	# 4183	# 4184	# 4185	# 4186
12"	# 4191	# 4192	# 4193	# 4194	# 4195	# 4196

PVDF (KYNAR®)						
Size	Thickness					
	1/2"	3/4"	1"	1 1/4"	1 1/2"	2"
1"	# 4211	# 4212	# 4213	# 4214	# 4215	# 4216
1 1/2"	# 4221	# 4222	# 4223	# 4224	# 4225	# 4226
2"	# 4231	# 4232	# 4233	# 4234	# 4235	# 4236
3"	# 4241	# 4242	# 4243	# 4244	# 4245	# 4246
4"	# 4251	# 4252	# 4253	# 4254	# 4255	# 4256
6"	# 4261	# 4262	# 4263	# 4264	# 4265	# 4266
8"	# 4271	# 4272	# 4273	# 4274	# 4275	# 4276
10"	# 4281	# 4282	# 4283	# 4284	# 4285	# 4286
12"	# 4291	# 4292	# 4293	# 4294	# 4295	# 4296

TEFLON®						
Size	Thickness					
	1/2"	3/4"	1"	1 1/4"	1 1/2"	2"
1"	# 4311	# 4312	# 4313	# 4314	# 4315	# 4316
1 1/2"	# 4321	# 4322	# 4323	# 4324	# 4325	# 4326
2"	# 4331	# 4332	# 4333	# 4334	# 4335	# 4336
3"	# 4341	# 4342	# 4343	# 4344	# 4345	# 4346
4"	# 4351	# 4352	# 4353	# 4354	# 4355	# 4356
6"	# 4361	# 4362	# 4363	# 4364	# 4365	# 4366
8"	# 4371	# 4372	# 4373	# 4374	# 4375	# 4376
10"	# 4381	# 4382	# 4383	# 4384	# 4385	# 4386
12"	# 4391	# 4392	# 4393	# 4394	# 4395	# 4396

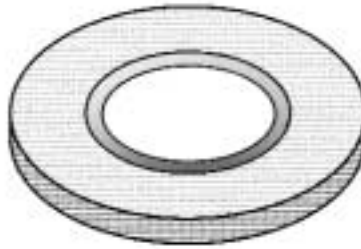

POLYPROPYLENE						
Size	Thickness					
	1/2"	3/4"	1"	1 1/4"	1 1/2"	2"
1"	# 5111	# 5112	# 5113	# 5114	# 5115	# 5116
1 1/2"	# 5121	# 5122	# 5123	# 5124	# 5125	# 5126
2"	# 5131	# 5132	# 5133	# 5134	# 5135	# 5136
3"	# 5141	# 5142	# 5143	# 5144	# 5145	# 5146
4"	# 5151	# 5152	# 5153	# 5154	# 5155	# 5156
6"	# 5161	# 5162	# 5163	# 5164	# 5165	# 5166
8"	# 5171	# 5172	# 5173	# 5174	# 5175	# 5176
10"	# 5181	# 5182	# 5183	# 5184	# 5185	# 5186
12"	# 5191	# 5192	# 5193	# 5194	# 5195	# 5196

PVDF (KYNAR®)						
Size	Thickness					
	1/2"	3/4"	1"	1 1/4"	1 1/2"	2"
1"	# 5211	# 5212	# 5213	# 5214	# 5215	# 5216
1 1/2"	# 5221	# 5222	# 5223	# 5224	# 5225	# 5226
2"	# 5231	# 5232	# 5233	# 5234	# 5235	# 5236
3"	# 5241	# 5242	# 5243	# 5244	# 5245	# 5246
4"	# 5251	# 5252	# 5253	# 5254	# 5255	# 5256
6"	# 5261	# 5262	# 5263	# 5264	# 5265	# 5266
8"	# 5271	# 5272	# 5273	# 5274	# 5275	# 5276
10"	# 5281	# 5282	# 5283	# 5284	# 5285	# 5286
12"	# 5291	# 5292	# 5293	# 5294	# 5295	# 5296

TEFLON®						
Size	Thickness					
	1/2"	3/4"	1"	1 1/4"	1 1/2"	2"
1"	# 5311	# 5312	# 5313	# 5314	# 5315	# 5316
1 1/2"	# 5321	# 5322	# 5323	# 5324	# 5325	# 5326
2"	# 5331	# 5332	# 5333	# 5334	# 5335	# 5336
3"	# 5341	# 5342	# 5343	# 5344	# 5345	# 5346
4"	# 5351	# 5352	# 5353	# 5354	# 5355	# 5356
6"	# 5361	# 5362	# 5363	# 5364	# 5365	# 5366
8"	# 5371	# 5372	# 5373	# 5374	# 5375	# 5376
10"	# 5381	# 5382	# 5383	# 5384	# 5385	# 5386
12"	# 5391	# 5392	# 5393	# 5394	# 5395	# 5396

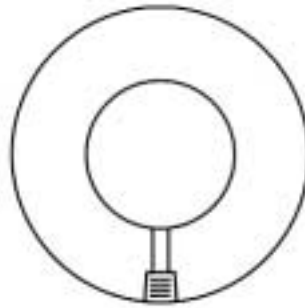

POLYPROPYLENE						
Size	Thickness					
	1/2"	3/4"	1"	1 1/4"	1 1/2"	2"
1"	# 7111	# 7112	# 7113	# 7114	# 7115	# 7116
1 1/2"	# 7121	# 7122	# 7123	# 7124	# 7125	# 7126
2"	# 7131	# 7132	# 7133	# 7134	# 7135	# 7136
3"	# 7141	# 7142	# 7143	# 7144	# 7145	# 7146
4"	# 7151	# 7152	# 7153	# 7154	# 7155	# 7156
6"	# 7161	# 7162	# 7163	# 7164	# 7165	# 7166
8"	# 7171	# 7172	# 7173	# 7174	# 7175	# 7176
10"	# 7181	# 7182	# 7183	# 7184	# 7185	# 7186
12"	# 7191	# 7192	# 7193	# 7194	# 7195	# 7196

PVDF (KYNAR®)						
Size	Thickness					
	1/2"	3/4"	1"	1 1/4"	1 1/2"	2"
1"	# 7211	# 7212	# 7213	# 7214	# 7215	# 7216
1 1/2"	# 7221	# 7222	# 7223	# 7224	# 7225	# 7226
2"	# 7231	# 7232	# 7233	# 7234	# 7235	# 7236
3"	# 7241	# 7242	# 7243	# 7244	# 7245	# 7246
4"	# 7251	# 7252	# 7253	# 7254	# 7255	# 7256
6"	# 7261	# 7262	# 7263	# 7264	# 7265	# 7266
8"	# 7271	# 7272	# 7273	# 7274	# 7275	# 7276
10"	# 7281	# 7282	# 7283	# 7284	# 7285	# 7286
12"	# 7291	# 7292	# 7293	# 7294	# 7295	# 7296

TEFLON®						
Size	Thickness					
	1/2"	3/4"	1"	1 1/4"	1 1/2"	2"
1"	# 7311	# 7312	# 7313	# 7314	# 7315	# 7316
1 1/2"	# 7321	# 7322	# 7323	# 7324	# 7325	# 7326
2"	# 7331	# 7332	# 7333	# 7334	# 7335	# 7336
3"	# 7341	# 7342	# 7343	# 7344	# 7345	# 7346
4"	# 7351	# 7352	# 7353	# 7354	# 7355	# 7356
6"	# 7361	# 7362	# 7363	# 7364	# 7365	# 7366
8"	# 7371	# 7372	# 7373	# 7374	# 7375	# 7376
10"	# 7381	# 7382	# 7383	# 7384	# 7385	# 7386
12"	# 7391	# 7392	# 7393	# 7394	# 7395	# 7396

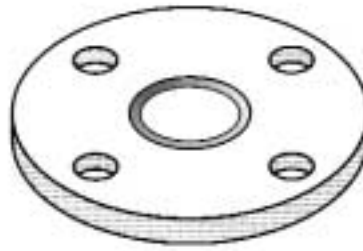

POLYPROPYLENE						
Size	Thickness					
	1/2"	3/4"	1"	1 1/4"	1 1/2"	2"
1"	# 6111	# 6112	# 6113	# 6114	# 6115	# 6116
1 1/2"	# 6121	# 6122	# 6123	# 6124	# 6125	# 6126
2"	# 6131	# 6132	# 6133	# 6134	# 6135	# 6136
3"	# 6141	# 6142	# 6143	# 6144	# 6145	# 6146
4"	# 6151	# 6152	# 6153	# 6154	# 6155	# 6156
6"	# 6161	# 6162	# 6163	# 6164	# 6165	# 6166
8"	# 6171	# 6172	# 6173	# 6174	# 6175	# 6176
10"	# 6181	# 6182	# 6183	# 6184	# 6185	# 6186
12"	# 6191	# 6192	# 6193	# 6194	# 6195	# 6196

PVDF (KYNAR®)						
Size	Thickness					
	1/2"	3/4"	1"	1 1/4"	1 1/2"	2"
1"	# 6211	# 6212	# 6213	# 6214	# 6215	# 6216
1 1/2"	# 6221	# 6222	# 6223	# 6224	# 6225	# 6226
2"	# 6231	# 6232	# 6233	# 6234	# 6235	# 6236
3"	# 6241	# 6242	# 6243	# 6244	# 6245	# 6246
4"	# 6251	# 6252	# 6253	# 6254	# 6255	# 6256
6"	# 6261	# 6262	# 6263	# 6264	# 6265	# 6266
8"	# 6271	# 6272	# 6273	# 6274	# 6275	# 6276
10"	# 6281	# 6282	# 6283	# 6284	# 6285	# 6286
12"	# 6291	# 6292	# 6293	# 6294	# 6295	# 6296

TEFLON®						
Size	Thickness					
	1/2"	3/4"	1"	1 1/4"	1 1/2"	2"
1"	# 6311	# 6312	# 6313	# 6314	# 6315	# 6316
1 1/2"	# 6321	# 6322	# 6323	# 6324	# 6325	# 6326
2"	# 6331	# 6332	# 6333	# 6334	# 6335	# 6336
3"	# 6341	# 6342	# 6343	# 6344	# 6345	# 6346
4"	# 6351	# 6352	# 6353	# 6354	# 6355	# 6356
6"	# 6361	# 6362	# 6363	# 6364	# 6365	# 6366
8"	# 6371	# 6372	# 6373	# 6374	# 6375	# 6376
10"	# 6381	# 6382	# 6383	# 6384	# 6385	# 6386
12"	# 6391	# 6392	# 6393	# 6394	# 6395	# 6396

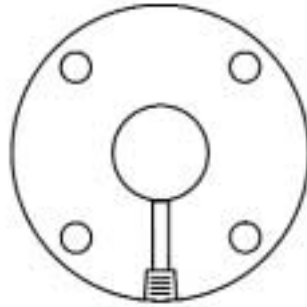

POLYPROPYLENE						
Size	Thickness					
	1/2"	3/4"	1"	1 1/4"	1 1/2"	2"
1"	# 8111	# 8112	# 8113	# 8114	# 8115	# 8116
1 1/2"	# 8121	# 8122	# 8123	# 8124	# 8125	# 8126
2"	# 8131	# 8132	# 8133	# 8134	# 8135	# 8136
3"	# 8141	# 8142	# 8143	# 8144	# 8145	# 8146
4"	# 8151	# 8152	# 8153	# 8154	# 8155	# 8156
6"	# 8161	# 8162	# 8163	# 8164	# 8165	# 8166
8"	# 8171	# 8172	# 8173	# 8174	# 8175	# 8176
10"	# 8181	# 8182	# 8183	# 8184	# 8185	# 8186
12"	# 8191	# 8192	# 8193	# 8194	# 8195	# 8196

PVDF (KYNAR®)						
Size	Thickness					
	1/2"	3/4"	1"	1 1/4"	1 1/2"	2"
1"	# 8211	# 8212	# 8213	# 8214	# 8215	# 8216
1 1/2"	# 8221	# 8222	# 8223	# 8224	# 8225	# 8226
2"	# 8231	# 8232	# 8233	# 8234	# 8235	# 8236
3"	# 8241	# 8242	# 8243	# 8244	# 8245	# 8246
4"	# 8251	# 8252	# 8253	# 8254	# 8255	# 8256
6"	# 8261	# 8262	# 8263	# 8264	# 8265	# 8266
8"	# 8271	# 8272	# 8273	# 8274	# 8275	# 8276
10"	# 8281	# 8282	# 8283	# 8284	# 8285	# 8286
12"	# 8291	# 8292	# 8293	# 8294	# 8295	# 8296

TEFLON®						
Size	Thickness					
	1/2"	3/4"	1"	1 1/4"	1 1/2"	2"
1"	# 8311	# 8312	# 8313	# 8314	# 8315	# 8316
1 1/2"	# 8321	# 8322	# 8323	# 8324	# 8325	# 8326
2"	# 8331	# 8332	# 8333	# 8334	# 8335	# 8336
3"	# 8341	# 8342	# 8343	# 8344	# 8345	# 8346
4"	# 8351	# 8352	# 8353	# 8354	# 8355	# 8356
6"	# 8361	# 8362	# 8363	# 8364	# 8365	# 8366
8"	# 8371	# 8372	# 8373	# 8374	# 8375	# 8376
10"	# 8381	# 8382	# 8383	# 8384	# 8385	# 8386
12"	# 8391	# 8392	# 8393	# 8394	# 8395	# 8396

Typical Physical Properties of Lucite® Cast Acrylic Sheet*^①

Property		Method	Value
	Thickness, Nominal, Inch		0.236
	Specific Gravity	ASTM D792	1.19
Optical	Refractive Index	ASTM D542	1.49
	Light Transmittance	ASTM D1003	
	Parallel		91%
	Total		92%
	Haze		1%
	Spectral transmission 290 to 330 nm, 0.25" sheet, max, percent	ASTM DU-792 Beckman	5%
Mechanical	Tensile Strength	ASTM D638	
	Rupture		11M psi (760 kg/cm ²)
	Modulus of Elasticity		564M psi (3 x 10 ⁴ kg/cm ²)
	Elongation at Rupture		4.1%
	Flexural Strength	ASTM D790	
	Rupture		14.8M psi (1,050 kg/cm ²)
	Modulus of Elasticity		450M psi (3 x 10 ⁴ kg/cm ²)
	Compressive Strength	ASTM D695	
	Yield		14.8M psi (1,260 kg/cm ²)
	Modulus of Elasticity		279M psi (3 x 10 ⁴ kg/cm ²)
	Shear Strength	ASTM D732	8.4M psi (630 kg/cm ²)
	Impact Strength	ASTM D256	
	Charpy Unnotched		5.0 ft. lb./in. ² (0.48 kg/cm ²)
	Rockwell Hardness	ASTM D785	M-100
Thermal	Hot Forming Temperature		275-350°F (135-175°C)
	Heat Distortion Temperature 3.6°F (2°C)/Min-264 psi	ASTM D648	200°F (93°C)*
	Coefficient of Thermal Expansion (ave. value) ^②	ASTM D696	3.9 x 10 ⁻⁵ in./in./ °F (7 x 10 ⁻⁵ cm/cm/°C)
	Maximum Recommended Continuous Service Temperature		180°F (82°C)
	Coefficient of Thermal Conductivity		1.45 Btu in./ft ² hr. °F (5 x 10 ⁻⁴ Cal/sec.cm ² °C/cm)
	Shrinkage, max. percent		2.5%
	Specific heat		0.35 Btu/lb. °F (0.35 Cal/gr °C)
Electrical	Surface Resistivity, 82°F (28°C), 75% RH	ASTM D257	>10 ¹⁴ ohm
	Volume Resistivity	ASTM D257	4 x 10 ¹¹ ohm/mil (10 ¹⁵ ohm/cm)
	Dielectric Strength, Short Time Test	ASTM D149	0.42 kv/mil (20 kv/mm)
	Dielectric Constant	ASTM D150	
	60 cycles		4
	10 ³ cycles		3
	10 ⁶ cycles		3
	Power Factor	ASTM D150	
	60 cycles		0.06
	10 ³ cycles		0.04
	10 ⁶ cycles		0.02
	Arc Resistance	ASTM D495	No Tracking
Miscellaneous	Water Absorption (Wt. Gain on Immersion for 24 hrs.)	ASTM D570	0.3%
	Soluble Matter Lost after Immersion	ASTM D570	0.0%
	Odor		None
	Taste		None
Combustibility*	Smoke Density Rating	ASTM D2843	13.5%
	UL Horizontal Burning Rate	UL 94	94 HB

LUCITE cast acrylic sheet is combustible like many other synthetic and natural building materials. Small scale tests are not intended to reflect hazards under actual fire conditions.

* This value changes with thickness. Value given is for 0.236" thickness or where otherwise indicated.

① These are typical or average values and should not be used for specification purposes.

② Change in dimensions = coefficient x (dimension of sheet) x (change in temperature).

Typical Property Values* of LEXAN® Polycarbonate Sheet

Property		Method	Units	Value
Physical	Specific Gravity	ASTM D792	-	1.20
	Refractive Index @77°F	ASTM D542A	-	1.586
	Light Transmission (Average), 1/8" disk	ASTM D1003	%	88
	Rockwell Hardness	ASTM D785	-	M70
	Abrasion Resistance, Taber Abrader, CS-17 wheel	ASTM D1044	mg/1,000 cycles	10
	Water Absorption, Equilibrium, 24 hrs	ASTM D570	%	0.15
	73°F			0.35
	212°F			0.58
Mechanical	Tensile Strength	ASTM D638	psi	
	@ Yield			9,000
	Ultimate			9,500
	Tensile Modulus	ASTM D638	psi	345,000
	Flexural Strength	ASTM D790	psi	13,500
	Flexural Modulus	ASTM D790	psi	345,000
	Flexural Modulus @ 1,800 cycles/min, 73°F, 50% RH	ASTM D671	psi	1,000
	Compressive Strength	ASTM D695	psi	12,500
	Compressive Modulus	ASTM D695	psi	345,000
	Elongation	ASTM D638	%	110
	Poisson's Ratio	-	-	0.37
	Izod Impact Strength	D256A	ft-lbs/in	
	Notched @ 1/8"			12-16
	Unnotched @ 1/8"			30 (no-failure)
	Tensile Impact Strength, S-Type Specimen	ASTM 1822	ft-lbs/in ²	225-300
Shear Strength	@ Yield	ASTM D732	psi	6,000
	Ultimate			10,000
Shear Modulus	ASTM D732	psi	114,000	
Deformation Under Load @ 4,000 psi	73°F	ASTM D621	%	0.2
	158°F			0.3
Thermal	Coefficient of Thermal Expansion	ASTM D696	in/in/°F	3.75 x 10 ⁻⁵
	Coefficient of Thermal Conductivity	ASTM C177	Btu/hr/ft ² /°F/in	1.35
	Specific Heat @ 40°F		cal/gm/°C	0.30
	Heat Deflection Temperature	ASTM D648	°F	
	@ 264 psi			270
@ 66 psi			280	
Brittle Temperature	ASTM D746	°F	-211	
Electrical	Dielectric Strength	ASTM D150	-	
	@ 10 Hz			2.96
	@ 60 Hz			3.17
	Volume Resistivity	ASTM D257	ohm-cm	8.2 x 10 ¹⁶
	Power Factor	ASTM D150		
@60Hz			0.0009	
1,000,000 Hz			0.010	
Arc Resistance	Stainless Steel Strip Electrodes	ASTM D495	sec	10-11
	Tungsten Electrodes			120
Flammability	Horizontal Burn (Flame Spread) AEB	ASTM D635	in	<1

* These are typical properties and are not intended for specification purposes.

Average Physical Properties of Plexiglas® Sheet¹

Property		Method ²	Units	Plexiglas G	Plexiglas MC
	Thickness, nominal		in	0.236	0.236
	Specific gravity	ASTM D792	N/A	1.19	1.19
Optical	Refractive Index	ASTM D542	N/A	1.49	1.49
	Light Transmittance and haze "as received"	ASTM D1003			
	Parallel		%	91*	91*
	Total		%	92*	92*
	Haze		%	1*	1*
	Ultraviolet transmission, 320 nm	ASTM DU-792 Beckman	%	0	0
Mechanical	Tensile strength (1/4 in. specimen - 0.2 in/min)	ASTM D638			
	Maximum		psi	10,500	10,200
	Rupture		psi	10,500	10,200
	Elongation, maximum		%	4.9	4.5
	Elongation, rupture		%	4.9	4.5
	Modulus of elasticity		psi	450,000	450,000
	Poisson's ratio			0.35	-
	Flexural strength (span depth ratio 16, 0.1 in/min)	ASTM D790			
	Maximum		psi	16,000	15,000
	Rupture		psi	16,000	15,000
	Deflection, maximum		in	0.6	0.5
	Deflection, rupture		in	0.6	0.5
	Modulus of Elasticity		psi	450,000	450,000
	Compressive strength (0.05 in/min)	ASTM D695			
	Maximum		psi	18,000	16,000
	Modulus of Elasticity		psi	450,000	430,000
	Compressive deformation under load	ASTM D621			
	2,000 psi at 122° F 24 hrs	Method A	%	0.2	0.3
	4,000 psi at 122° F 24 hrs (conditioned 48 hrs at 122°F)		%	0.5	0.9
	Shear Strength	ASTM D732	psi	9,000	
	Shear Modulus		psi	167,000	
	Impact Strength	ASTM D256			
	Charpy unnotched @ 73°F		ft-lb/1/2 in. x 1 in. sect. ft-lb/in of notch	7.0	7.0
	Izod milled notch @ 73°F			0.4	0.4
	Rockwell Hardness	ASTM D785	-	M-100*	M-90*
Thermal	Hot forming temperature		°F	290-360	275-350
	Deflection temperature under (flexural) load	ASTM D648			
	3.6°F/min-264 psi		°F	205	200*
	Maximum recommended continuous service temp.		°F	180-200	170-190
	Coefficient of thermal expansion	R & H P4A	in/in/° X 10 ⁵		
	-40°F			2.8	2.7
	-20°F			2.9	2.9
	0			3.1	3.1
	20			3.3	3.2
	40			3.6	3.4
	60			3.9	3.6
	80			4.2	3.9
	100			4.6	4.3
		Cenco-Fitch		1.3	1.3

* This value will change with thickness. The value given is for the thickness indicated in the column heading.

¹ Values reported are averages and should not be used for specification purposes.

² Samples conditioned per ASTM D618, Procedure B, except where noted.

N.A. = Not applicable

Average Physical Properties of Plexiglas® Sheet¹ (continued)

Property		Method ²	Units	Plexiglas G	Plexiglas MC
Thermal (cont.)	Coefficient of thermal conductivity		BT/ (hr) (sq ft) (°F/in)		
	Specific heat at 77°F		BTU/ (lb)(°F)	0.35	0.35
Electrical	Dielectric strength, short time test	ASTM D149	volts/mill	500	500
	Dielectric constant	ASTM D150			
	60 Hz			3.73.	33 3.73/7
	1,000 Hz			3.3	3.3
	1,000,000 Hz			2.5	2.5
	Power factor	ASTM D150			
	60 Hz			0.05	0.05
	1,000 Hz			0.04	0.04
	1,000,000 Hz			0.03	0.03
	Arc resistance	ASTM D495		No Tracking	No Tracking
	Volume resistivity	ASTM D257	ohm-cm	6 x 10 ¹⁷	1 x 10 ¹⁸
	Surface resistivity	ASTM D257	ohm/sq cm	2 x 10 ¹⁸	1 x 10 ¹⁷
Miscellaneous	Horizontal burning test average	ASTM D635	cm/min	2.8	2.5
	Burning rate		(in/min)	(1.1*)	(1.0*)
	Smoke Density	ASTM D2843	%	4-10	4-10
	Flammability classification		UL 94	94HB	94HB
	Water absorption (weight gain) after immersion for:				
	1 day (24 hours)		%	0.2*	-
	Soluble matter lost		%	0.2*	0.3*
	Odor			None	None
	Taste			None	None

* This value will change with thickness. The value given is for the thickness indicated in the column heading.

¹ Values reported are averages and should not be used for specification purposes.

² Samples conditioned per ASTM D618, Procedure B, except where noted.

N.A. = Not applicable

Typical Properties* of PVC Sheet

Property		Method	Units	Value
Physical	Density	ASTM D792	g/cm ³	1.42
	Water Absorption	ASTM D570	%	0.06
	Rockwell Hardness	ASTM D785	R Scale	115
	Shore Durometer	ASTM D2240	D	89
	Cell Class	1784	--	12454-B
Mechanical	Tensile Modulus	ASTM D638	psi	411,000
	Yield Strength	ASTM D638	psi	7,500
	Flexural Modulus	ASTM D790	psi	481,000
	Yield Strength	ASTM D790	psi	12,800
	Izod Impact	ASTM D256	ft-lbs/in	1.0
Thermal	Vicat Softening Point	ASTM D1525	°C/°F	83/181
	Heat Deflection Temperature	ASTM D648	°C/°F	82/179
	Heat Deflection Temperature	ASTM D648	°C/°F	80/176
	Linear Coefficient of Expansion	ASTM D696	in/in/°C	5.8 x 10 ⁻⁵
	Linear Coefficient of Expansion	ASTM D696	in/in/°F	3.2 x 10 ⁻⁵
Flammability	Flammability	ASTM D635	--	Self-Extinguishing
	Flammability	UL 94V	--	0
	Flame Spread	E84	--	15
Chemical	Chemical Resistance	ASTM 1784	--	Class B
Electrical	Electrical Volume Resistivity	ASTM D257	Ohm/cm	5.4 x 10 ¹⁵
	Dielectric Constant	ASTM D150	60 Hz	3.19
	Dissipation Factor	ASTM D150	60 Hz	0.0096
	Loss Index	ASTM D150	60 Hz	0.030
	Dielectric Strength	ASTM D149	Volts/mil	544

*These are "Typical" properties and are not intended for specification purposes.

Typical Property Values of CORZAN™ CPVC Sheet

Property		Method	Units	Value ¹
Physical	Specific Gravity	ASTM D792	g/cm ³	1.55
	Water Absorption	ASTM D570	%	.03
	Rockwell Hardness	ASTM D785	R Scale	119
	Cell Class	ASTM D1784	--	23447-B
Mechanical	Izod Impact (Notched)	ASTM D256	ft-lb/in o.n.	1.5
	Tensile Strength	ASTM D638	psi	8,000
	Flexural Strength	ASTM D790	psi	15,100
	Flexural Modulus	ASTM D790	psi	415,000
	Compressive Strength	ASTM D695	psi	10,100
	Compressive Modulus	ASTM D695	psi	196,000
Thermal	Coefficient of Thermal Expansion	ASTM D696	in/in/°F	3.4 x 10 ⁻⁵
	Thermal Conductivity	ASTM C177	BTU/in/hr/ft ² /°F	0.95
	Heat Distortion Temperature @ 264 psi	ASTM D648	°C/°F	103/217
Flammability	Flammability	UL 94	V-0, 5VB, 5VA	0.062"
	Flame Spread	E84	--	15
	Smoke Developed	E84	--	70-125
	Limiting Oxygen Index	ASTM D2863	%	60
Electrical	Dielectric Strength	ASTM D147	Volt/MIL	1250
	Dielectric Constant	ASTM D150	60 Hz	3.70
	Power Factor	ASTM D150	1000 Hz	0.007%
	Volume Resistivity	ASTM D257	Ohm/cm	3.4 x 10 ¹⁵

¹These are "Typical" properties and are not intended for specification purposes.

Typical Property Values* of High Density Polyethylene

Property	Method	Units	Value
ASTM Type, Class, Category	ASTM D1248	-	IV, A, 4
Melt Index	ASTM D1238	g/10 min.	0.70
Density	ASTM D1505	g/cm ³	.960
Hardness	ASTM D2240	Shore D	68
Tensile Strength @ Break	ASTM D638	psi	4,400
Elongation @ Break	ASTM D638	%	>600
Flexural Modulus	ASTM D790	psi	220,000
1% Scant Modulus	ASTM D790	psi	--
Tensile Impact, (2)	ASTM D1822	ft-lb/in	100
Environment Stress Crack Resistance, F50	ASTM D1693	hrs.	--
Low Temperature Brittleness, F50	ASTM D2561	hrs.	--
Heat Deflection Temperature @ 66 PSI	ASTM D746	°C	<.76
Vicat Softening Point	ASTM D648	°C	78
	ASTM D1525	°C	125

Black Pipe Grade High Density Polyethylene

Property	Method	Units	Value
ASTM Type, Class, Category, Grade	ASTM D1248	--	III, A, 5, P34
Cell Classification	ASTM D3350	--	345,434
PPI Recommended Designation	--	PE 3408	--
Density	ASTM D792	g/cm ²	.957
Melting Point	ASTM D3417	°F	260
Reduced Specific Viscosity (RSV)	ASTM D1601	dl/g	3.0
Melt Flow Indices 190°C/5kg	ASTM D1238	g/10 min	0.4
Melt Flow Indices 109°C/21.6kg (HM1)	ASTM D1238	g/10 min	10
Hydrostatic Design Basis 100,000 hrs. 73°F (23°C)	ASTM D2837	psi	1,600
Compressed Ring ESCR (50°C/25% Igepal)	ASTM F1248	hrs.	>1,000 (no failures)
Rockwell Hardness	ASTM D785	L Scale	49
Shore Hardness	ASTM D2240	Shore D	63
ESCR (100% Igepal)	ASTM D1693C	hrs.	>5,000 (no failures)
Izod Impact Strength (Notched)	ASTM D256A§	ft-lb/in	8
Tensile Strength @ Yield	ASTM D638‡	psi	>3,300
Elongation @ Break	ASTM D638‡	%	>800
Scant Modulus of Elasticity @ 2% Strain	ASTM D638‡	psi	115,000
Flexural Modulus @ 2% Strain	ASTM D3350	psi	125,000
Vicat Softening Point	ASTM D1525	°F	255
Brittleness Temperature	ASTM D746	°F	-180
Heat Distortion Temperature	ASTM D648	°F	172
Thermal Expansion	ASTM D696	in/in/°F	1 x 10 ⁻¹

* The data listed above was determined on press molded test specimens and may, therefore, vary from the specimens taken from pipes and sheet. ‡ Type IV specimen, 2 in/min. §1/8" thick specimen. FDA Registered. N550 Carbon Black, NSF Approved for potable water UV Stabilized 2.5% Carbon Black ± 0.5%.

Physical Properties UHMWPE

Property	Method	SI Units	SI Value	English Unit	English Value
Density	ASTM D792	kg/m ³	930	lbs/ft ³	58.01
Yield Point	ASTM D638	MPa	21	psi	3050
Elongation at Yield	ASTM D638	%	15	%	15
Tensile Break	ASTM D638	MPa	36	psi	5800
Elongation at Break	ASTM D638	%	200	%	200
Tensile Modulus	ASTM D638	MPa	820	psi	120000
Flexural Modulus	ASTM D790	MPa	760	psi	110000
Izod Impact	ASTM D4020	kJ/m ²	50	ft-lbs/in ²	24
Tensile Impact	DIN 53448	kJ/m ²	1500	ft-lbs/in ²	715
Sand Wheel Wear	ASTM G-65	T-1000=100	100	T-1000=100	100
Hardness	ASTM D2240	Shore D	68	Shore D	68
Static Friction	ASTM D1894	Unitless	0.15	Unitless	0.15
Dynamic Friction	ASTM D1894	Unitless	0.12	Unitless	0.12
Coefficient of Thermal Expansion	ASTM D696	°C ⁻¹	0.0002	°F ⁻¹	0.00011
Melt Point	ASTM D3417	°C	137-143	°F	278-289
Maximum Operating Temperature		°C	62	°F	180
Compressive Modulus	ASTM D695	MPa	536	psi	77750
Compressive Deformation	ASTM D621	% at 454.5 kg	6-8	% at 1000 psi	6-8
Volume Resistivity	ASTM D257	Ohm-cm	>10 ¹⁵	Ohm-cm	>10 ¹⁵
Surface Resistivity	ASTM D257	Ohm	>10 ¹⁵	Ohm	>10 ¹⁵
Water Absorption	ASTM D570	%	nil	%	nil

Values are averages and are not specifications.

ASTM test methods are under current procedures.

CPG Seaboard™ Typical Properties*

Property		Method	Units	Value
Physical	Density	ASTM D1505	g/cm ³	.960
	Melt Index	ASTM D1238	g/10 min	0.7
	Hardness, Shore D	ASTM D2240		68
	Environmental Stress Crack	ASTM D1693	hrs.	25
	Resistance, F50	ASTM D2561	hrs.	>500
Mechanical	Tensile Strength @ Break	ASTM D638	psi	4,400
	Elongation @ Break	ASTM D638	%	>600
	Flexural Modulus	ASTM D790	psi	220,000
	Tensile Impact	ASTM D1822	ft-lb/in	100
Thermal	Low Temperature Brittleness, F50	ASTM D746	°C	<-76
	Heat Deflection Temperature @ 66 PSI	ASTM D648	°C	78
	Vicat Softening Point	ASTM C1525	°C	125

CPG Seaboard™ meets all the requirements of the Food and Drug Administration regulation 21 CFR 177.1520 for articles intended for use in direct contact with foodstuffs. CPG Seaboard™ is ultraviolet stabilized.

*These are "Typical" properties and are not intended for specification purposes.

Typical Properties* Polypropylene Sheet

Property		Method	Units	Value ⁽¹⁾
Physical	Density ⁽³⁾	ASTM D792	g/cm ³	.905
	Nominal Melt Flow ⁽²⁾	ASTM D1238	g/10 min	0.6
	Rockwell Hardness	ASTM D785	R Scale	92
	Melting Point ⁽⁶⁾	Aristech	°C/°F	164/327
Mechanical	Tensile Strength @ Yield ⁽⁴⁾	ASTM D638	psi	4800
			MPa	33
	Elongation @ Yield ⁽⁴⁾	ASTM D638	%	14
	Flexural Modulus	ASTM D790A	psi	195,000
			MPa	1344
Izod Impact ⁽⁵⁾ Notched @ 73°F (23°C)	ASTM D256	ft-lb/in J/m	1.2 64	

(1) Injection Molded Specimens where applicable.

(2) 230 °C/2.16 kg

(3) at 73°F (23°C)

(4) Type I specimen at 2 in/min (50 mm/min) speed

(5) 1/8 inch (3.1752 mm) bar

(6) by DSC

Meets the standards established by FDA regulation 21 CFR 177.1250 for all food contact.

*These are "Typical" properties and are not intended for specification purposes.

Typical Properties of KYNAR® PVDF

Property		Method	Units	Value
Physical	Density	ASTM D792	lb/in ³	0.064
			g/cm ³	1.77
	Water Absorption, 24 hrs	ASTM D570	%	0.03
Mechanical	Tensile Strength	ASTM D638	psi	6,300
	Tensile Modulus	ASTM D638	psi	290,000
	Tensile Elongation @ Break	ASTM D638	%	50
	Flexural Strength	ASTM D790	psi	9,700
	Flexural Modulus	ASTM D790	psi	290,000
	Compressive Strength	ASTM D695	psi	9,000
	Compressive Modulus	ASTM D695	psi	--
	Hardness	ASTM D2240	Shore	D75
	IZOD Notched Impact	ASTM D256	ft-lb/in	3.0
	Thermal	Coefficient of Linear Thermal Expansion	ASTM D696	x 10 ⁻⁵ in/in/°F
Heat Deflection Temp @ 264 psi		ASTM D648	°F/°C	230/110
Melting Temp		ASTM D3418	°F/°C	332/166
Max Operating Temp		-	°F/°C	275/130
Thermal Conductivity		ASTM C177	BTU-in/ft ² -hr-°F x 10 ⁻⁴ cal/cm-sec-°C	0.70 2.41
	Flammability Rating	UL 94	--	V-O
Electrical	Dielectric Strength short time, 1/8" thick	ASTM D149	V/mil	1.7
	Dielectric Constant @ 1 Mhz	ASTM D150	1 MHz	8.5
	Dissipation Factor @ 1 MHz	ASTM D150	1 MHz	0.05
	Volume Resistivity @ 50% RH	ASTM D257	Ohm-cm	1.5 x 10 ¹⁵

Note: The information contained herein are typical values intended for reference and comparison purposes only. They should NOT be used as a basis for design specifications or quality control. All values at 73°F (23°C) unless otherwise noted.

Typical Properties* of HYLAR® PVDF

Property	Method	Units	Value
Melting Point	ASTM D3418	°C/°F	165-168 (329-334)
Melt Viscosity	ASTM D3835	@ 232°C, 100 s. ¹ (kilopoise)	18-21
Specific Gravity	ASTM D792	g/cc (lbs/in ³)	1.77-1.79 (.064-.065)
Moisture Absorption	ASTM D570	(%)	0.02
Hardness	ASTM D2240	Shore D	76-80
Tensile Strength @ Break @ 23°C Mpa	ASTM D638	psi	35-45 (5075-6525)
Tensile Strength @ Yield @ 23°C Mpa	ASTM D638	psi	35-48 (5075-6960)
Elongation @ Break @ 23°C	ASTM D638	%	50-250
Elongation @ Yield @ 23°C	ASTM D638	%	10
Tensile Modulus @ 23°C Mpa	ASTM D638	psi	1380-1725 (2x10 ⁵ to 2.5 x 10 ⁵)
Flexural Strength @ 23°C Mpa	ASTM D790	psi	48-55 (6960-8000)
Flexural Modulus @ 23°C Mpa	ASTM D790	psi	1380-2070 (2x10 ⁵ to 3 x 10 ⁵)
Heat Distortion Temperature @ 66 psi .46 Mpa	--	TMA °C (°F)	125-140 (257-284)
@ 264 psi 1.82 Mpa	--	°C (°F)	105-115 (221-240)
Compressive Strength @ 23°C Mpa (min)	ASTM D695	--	61 minimum (8850)
IZOD Impact @ 23°C Notched	ASTM D256	J/m (ft.lb./in)	80-130 (1.5-2.5)
Coefficient of Friction Static	ASTM D1894	--	0.15 - 0.25
Dynamic	ASTM D1894	--	0.10 - 0.25
Limiting Oxygen Index	ASTM D2863	%	43
Thermal Conductivity @ 23°C -130 °C W/m/k (BTU/in) / (HR/Ft/°F)	ASTM C177		0.19 - 0.22 (1.3-1.5)
Coefficient Thermal Expansion	ASTM D696	°C ⁻¹ (°F ⁻¹)	10-12 x 10 ⁻⁵ (5.6 - 6.7 x 10 ⁻⁵)
Specific Heat	DSC	J/g °C (BTU/lb °F)	1.9 (.45)
Brittleness Temperature	ASTM D2236	°C (°F)	-43 (-46)
Volume Resistivity	ASTM D257	ohm/cm (ohm/in)	1.4 x 10 (5.5 x 10 ¹⁵)
Arc Resistance, minimum	ASTM D495	(sec)	50
Dielectric Constant 60 kHz	ASTM D150	kHz	6.8
1 kHz		kHz	6.9
1 MHz		MHz	6.0
Dissipation Factor 60 Hz	ASTM D150	Hz	0.032
1 kHz		kHz	0.013
1 MHz		MHz	0.153
Dielectric Strength, 0.125" thickness V/mil (V/mil)	ASTM D149	310 (310)	--

*These are "Typical" properties and are not intended for specification purposes.

Typical Properties* of TEFLON® PTFE

Property		Method	Units	Value
Mechanical	Specific Gravity	ASTM D792	--	2.13-2.22
	Tensile Strength	ASTM D1457 ASTM D1708 ASTM D638	MPa (psi)	21-35 (3,000 - 5,000)
	Elongation	ASTM D1457 ASTM D1708 ASTM D638	%	300-500
	Flexural Modulus	ASTM D790	MPa (psi)	500 (72,000)
	Folding Endurance	ASTM D2176	(MIT) cycles	>10 ⁶
	Impact Strength	ASTM D256	J/m (ft-lb/in)	189 (3.5)
	Hardness	ASTM D2240	Shore D	50-65
	Coefficient of Friction, Dynamic	ASTM D1894	<3 m/min (<10 ft/min)	0.1
Thermal	Melting Point	ASTM D3418	°C (°F)	327 (621)
	Upper Service Temperature (20,000h)	UL746B	°C (°F)	260 (500)
	Flame Rating**	UL 94		VO
	Limiting Oxygen Index	ASTM D2863	%	>95
	Heat of Combustion	ASTM D240	MJ/kg (Btu/lb)	5.1 (2,200)
Electrical	Dielectric Constant	ASTM D150	1 MHz	2.1
	Dissipation Factor	ASTM D150	1 MHz	<0.0001
	Arc Resistance	ASTM D495	sec	>300
	Volume Resistivity	ASTM D257	ohm-cm	>10 ¹⁸
	Surface Resistivity	ASTM D257	ohm-sq	>10 ¹⁸
General	Weather Resistance	Florida Exposure	Years Unaffected	20
	Chemical/Solvent Resistance	ASTM D543		Excellent
	Water Absorption 24 h	ASTM D570	%	<0.01

* Typical values are unsuitable for specifications. Properties were measured at 23°C (73°F), unless otherwise noted.

** Statements regarding behavior in a flame situation are not intended to reflect hazards presented by this or any other material when under actual fire conditions.

Glassblowing

S. G. & P., Inc. has a full scale glassblowing facility which employs a highly skilled staff of glassblowers. We do custom fabrication of new glassware, as well as repair work.

We primarily use two types of glass in our fabrication: borosilicate and quartz. Borosilicate glass is also known under the brand names of Pyrex® (a registered trademark of Corning Glassworks) and Kimax® (a registered trademark of Kimble Glass Company). Pyrex® and Kimax® are used in the fabrication of most laboratory apparatus and are compatible when mixed. These glasses have a high resistance against chemical attack and thermal shock. Due to a low coefficient of expansion, mechanical breakage is minimized.

Quartz glass is transparent and contains 99.9% silica. Characterized by practically zero thermal expansion, quartz is not affected by thermal shock. Excellent uses for quartz include: furnace tubes, flat sight glasses requiring high temperature, or any high-temperature situation.



Table of Contents

Glassware

	Page Number
Adapters	47 - 59
Adapters, Threaded	60 - 61
Beakers	62
Bottles	62 - 64
Bubblers	64
Chromatography Columns	65 - 69
Condensers	70 - 74
Distillation Columns	75 - 77
Distillation Heads	78 - 80
Distillation Receivers	80 - 84
Evaporator Condensers	84 - 85
Evaporator Traps	86
Extractors	87 - 89
Flasks	90 - 106
Funnels	106 - 113
Gas Sampling	114 - 115
Impingers	115 - 116
Mantles	117 - 119
Reaction Apparatus	120 - 122
Reactors, Pilot Plant	122
Stirrers	123
Stoppers	123 - 124
Vacuum Manifolds	125
Vacuum Traps	125 - 126

Repairs

Due to the fragile nature of glassware, we cannot be responsible for any loss during repair efforts. Items sent in for repair should be thoroughly cleaned and securely packaged.

Specialty and Custom Glassware

We will be happy to quote on special items not found in the catalog or on modifications of listed glassware. Please provide drawings if possible.

2000 ADAPTER, STRAIGHT

Standard taper inner joints both ends.

<u>Part Number</u>	<u>Joint Size</u>	<u>Lengths Between Joints mm</u>
2000-01	24/40	30
2000-02	24/40	70
2000-03	24/40	120
2000-04	24/40	175
2000-05	29/26	30
2000-06	29/26	70
2000-07	29/42	30
2000-08	29/42	70
2000-09	29/42	120
2000-10	29/42	175



2000

2001 ADAPTER, STRAIGHT

Standard taper outer joints both ends.

<u>Part Number</u>	<u>Joint Size</u>	<u>Lengths Between Joints mm</u>
2001-01	24/40	30
2001-02	24/40	70
2001-03	24/40	120
2001-04	24/40	175
2001-05	29/26	30
2001-06	29/26	70
2001-07	29/42	30
2001-08	29/42	70
2001-09	29/42	120
2001-10	29/42	175



2001

SG & P offers adapters with different lengths and joint combinations than those listed. Call for more information.



2002

2002 ADAPTER, STRAIGHT, LENGTHENING

Standard taper top outer and lower inner joint.

<u>Part Number</u>	<u>Joint Size</u>	<u>Lengths Between Joints MM</u>
2002-01	14/20	30
2002-02	14/20	90
2002-03	24/40	30
2002-04	24/40	70
2002-05	24/40	120
2002-06	24/40	175
2002-07	29/42	30
2002-08	29/42	70
2002-09	29/42	120
2002-10	29/42	175

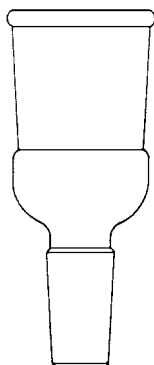

2003

2003 ADAPTER, ENLARGING

Standard taper joints. Lower inner joint is smaller is size than top outer joint.

<u>Part Number</u>	<u>Top Outer Joint</u>	<u>Lower Inner Joint</u>
2003-01	24/40	14/20
2003-02	24/40	14/35
2003-03	24/40	19/38
2003-04	29/42	14/35
2003-05	29/42	19/38
2003-06	29/42	24/40
2003-07	34/45	14/35
2003-08	34/45	19/38
2003-09	34/45	24/40
2003-10	34/45	29/42
2003-11	55/50	34/45
2003-12	55/50	45/50

SG & P offers adapters with different lengths and joint combinations than those listed. Call for more information.

Call **1-800-880-7722** Toll Free

2004 ADAPTER, REDUCING

Standard taper joints. Lower inner joint is larger in size than top outer joint.

Part Number	Top Outer Joint	Lower Inner Joint
2004-01	10/30	14/20
2004-02	10/30	14/35
2004-03	10/30	19/22
2004-04	10/30	24/40
2004-05	10/30	29/42
2004-06	10/30	34/45
2004-07	10/30	45/50
2004-08	14/20	24/40
2004-09	14/35	24/40
2004-10	14/35	29/42
2004-11	19/38	24/40
2004-12	19/38	29/42
2004-13	19/38	34/45
2004-14	19/38	45/50
2004-15	24/40	29/42
2004-16	24/40	34/45
2004-17	24/40	45/50
2004-18	29/42	34/45
2004-19	29/42	45/50

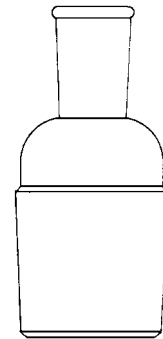

2004

2005 ADAPTER, COMBINATION

Top standard taper outer joint and lower ball joint.

Part Number	Joint Size	Lower Ball Joint
2005-01	24/40	28/15
2005-02	24/40	35/25
2005-03	29/42	28/15
2005-04	29/42	35/25

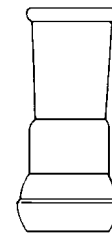

2005

2006 ADAPTER, COMBINATION

Top socket joint and lower standard taper inner joint.

Part Number	Top Socket Joint	Lower Inner Joints
2006-01	35/25	24/40
2006-02	35/25	29/42

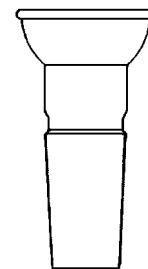

2006

SG & P offers adapters with different lengths and joint combinations than those listed. Call for more information.

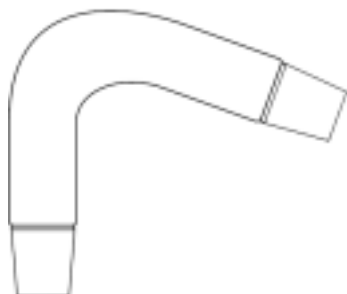

2007

2007 ADAPTER, DISTILLATION, 75°

Standard taper inner joints at a 75° angle.

<u>Part Number</u>	<u>Joint Size</u>
2007-01	14/20
2007-02	24/40
2007-03	29/42



2008

2008 ADAPTER, INLET, INNER JOINT

Standard taper inner joint. 10mm hose connection.

<u>Part Number</u>	<u>Joint Size</u>
2008-01	14/20
2008-02	24/40
2008-03	29/42

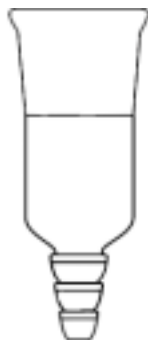

2009

2009 ADAPTER, INLET, OUTER JOINT

Standard taper outer joint. 10mm hose connection.

<u>Part Number</u>	<u>Joint Size</u>
2009-01	14/20
2009-02	24/40
2009-03	29/42

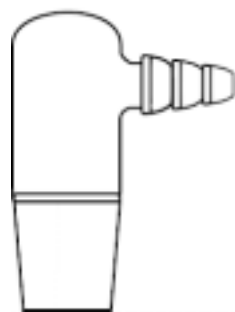

2010

2010 ADAPTER, INLET, INNER JOINT, 90°

Standard taper inner joint. 10mm hose connection at 90°.

<u>Part Number</u>	<u>Joint Size</u>
2010-01	14/20
2010-02	24/40
2010-03	29/42

SG & P offers adapters with different lengths and joint combinations than those listed. Call for more information.

Call **1-800-880-7722** Toll Free

2011 ADAPTER, INLET, INNER JOINT, 90°

Standard taper inner joint with extension to allow introduction of reactants below the interior surface. 10mm hose connection at 90°.

<u>Part Number</u>	<u>Joint Size</u>	<u>Length Below Joint MM</u>
2011-01	14/20	75
2011-02	24/40	200
2011-03	29/42	200



2011

2012 ADAPTER, INLET, FRITTED, INNER JOINT

Standard taper inner joint. Extra course disc between joint and 10mm hose connection.

<u>Part Number</u>	<u>Joint Size</u>
2012-01	14/20
2012-02	24/40
2012-03	29/42



2012

2013 ADAPTER, BUSHING

Standard taper inner joint with outer joint ground in the bore of the adapter.

<u>Part Number</u>	<u>Lower Inner Joint</u>	<u>Top Outer Joint</u>
2013-01	14/20	10/30
2013-02	14/35	10/30
2013-03	24/40	10/30
2013-04	29/42	10/30
2013-05	29/42	24/40



2013

2014 ADAPTER, CLAISEN

Parallel side arm for dual entry. Standard taper outer joints on top arms and lower inner joint.

<u>Part Number</u>	<u>Joint Size</u>
2014-01	14/20
2014-02	24/40
2014-03	29/42

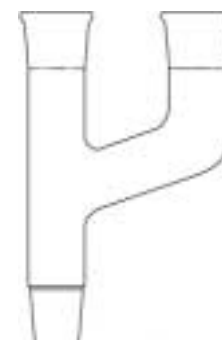

2014

SG & P offers adapters with different lengths and joint combinations than those listed. Call for more information.



2015

2015 ADAPTER, CLAISEN

Standard taper outer joint at top of main tube for use with a thermometer. Standard taper outer joint on side arm and inner joint at bottom.

<u>Part Number</u>	<u>Joint Size</u>	<u>Thermometer Joint Size</u>
2015-01	14/20	10/18
2015-02	24/40	10/30
2015-03	29/42	10/30

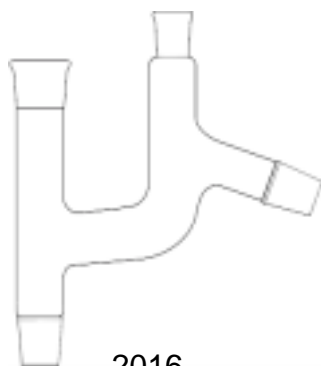

2016

2016 ADAPTER, DISTILLATION, CLAISEN

Distilling adapter with a standard taper 10/30 joint on the vertical side tube for a 75mm immersion thermometer.

<u>Part Number</u>	<u>Joint Size</u>
2016-01	24/40
2016-02	29/42

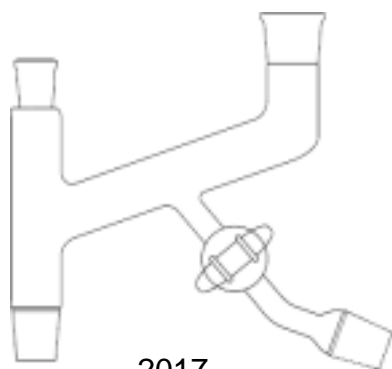

2017

2017 ADAPTER, DISTILLATION, CLAISEN

Stopcock on lower side tube and a standard taper 10/30 joint at the top of main tube for a 75mm immersion thermometer.

<u>Part Number</u>	<u>Joint Size</u>	<u>Stopcock Type</u>
2017-01	24/40	Glass
2017-02	24/40	Teflon
2017-03	29/42	Glass
2017-04	29/42	Teflon

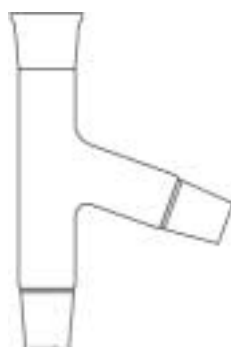

2018

2018 ADAPTER, DISTILLATION, 75°

Standard taper outer joint at top, inner joint at bottom and side.

<u>Part Number</u>	<u>Joint Size</u>
2018-01	14/20
2018-02	24/40
2018-03	29/42

SG & P offers adapters with different lengths and joint combinations than those listed. Call for more information.

2019 ADAPTER, DISTILLATION, 75°

Standard taper outer joint at top for use with a thermometer, inner joint at bottom and side.

<u>Part Number</u>	<u>Joint Size</u>	<u>Thermometer Joint Size</u>
2019-01	14/20	10/18
2019-02	24/40	10/30
2019-03	29/42	10/30

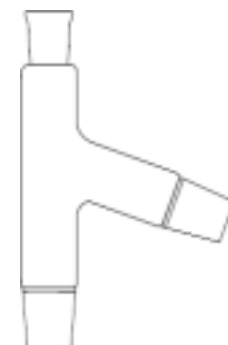

2019

2020 ADAPTER, 105°

Standard taper outer joints top and side, inner joint at bottom.

<u>Part Number</u>	<u>Joint Size</u>
2020-01	24/40
2020-02	29/42



2020

2021 ADAPTER, FLOW CONTROL, GLASS STOPCOCK, 90°

Standard taper inner joint. 2mm bore stopcock, 8mm hose connection.

<u>Part Number</u>	<u>Joint Size</u>
2021-01	14/20
2021-02	24/40
2021-03	29/42

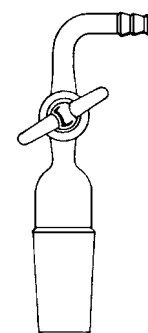

2021

2022 ADAPTER, FLOW CONTROL, TEFLON STOPCOCK, 90°

Standard taper inner joint. 2mm bore stopcock, 8mm hose connection.

<u>Part Number</u>	<u>Joint Size</u>
2022-01	14/20
2022-02	24/40
2022-03	29/42



2022

SG & P offers adapters with different lengths and joint combinations than those listed. Call for more information.

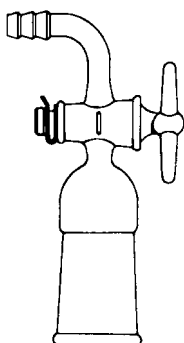

2023

2023 ADAPTER, FLOW CONTROL, GLASS STOPCOCK, 90°

Standard taper outer joint. 2mm bore stopcock, 8mm hose connection.

<u>Part Number</u>	<u>Joint Size</u>
2023-01	24/40
2023-02	29/42

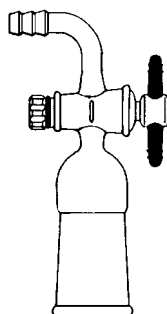

2024

2024 ADAPTER, FLOW CONTROL, TEFLON STOPCOCK, 90°

Standard taper outer joint. 2mm bore stopcock, 8mm hose connection.

<u>Part Number</u>	<u>Joint Size</u>
2024-01	24/40
2024-02	29/42



2025

2025 ADAPTER, FLOW CONTROL, GLASS STOPCOCK

Standard taper inner joint. 2mm bore stopcock, 8mm hose connection.

<u>Part Number</u>	<u>Joint Size</u>
2025-01	24/40
2025-02	29/42



2026

2026 ADAPTER, FLOW CONTROL, TEFLON STOPCOCK

Standard taper inner joint. 2mm bore stopcock, 8mm hose connection.

<u>Part Number</u>	<u>Joint Size</u>
2026-01	24/40
2026-02	29/42

SG & P offers adapters with different lengths and joint combinations than those listed. Call for more information.

Call **1-800-880-7722** Toll Free

2027 ADAPTER, FLOW CONTROL, TEFLON METERING STOPCOCK

Standard taper top outer and lower inner joints. 2mm metering stopcock.

Part Number	Joint Size
2027-01	14/20
2027-02	24/40
2027-03	29/42

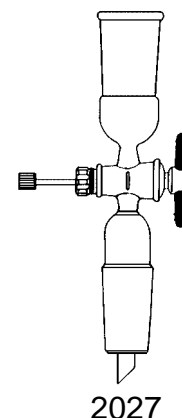

2028 ADAPTER, SYRINGE ADDITION

Standard taper top outer and lower inner joints. Supplied with one rubber septa.

Part Number	Joint Size
2028-01	14/20
2028-02	24/40
2028-03	29/42

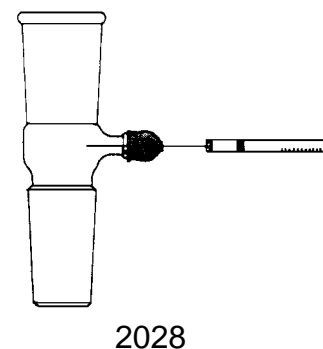

2029 ADAPTER, DISTILLING TRAP, KJELDAHL

Standard taper top outer and lower inner joints. Used above flask to prevent foaming type reactions from entering the distilling column or condenser.

Part Number	Joint Size
2029-01	14/20
2029-02	24/40
2029-03	29/42



2030 ADAPTER, VACUUM TAKE-OFF, VERTICAL

Standard taper top outer and lower inner joints with sealed in drip tip. 10mm hose connection.

Part Number	Joint Size
2030-01	14/20
2030-02	24/40
2030-03	29/42

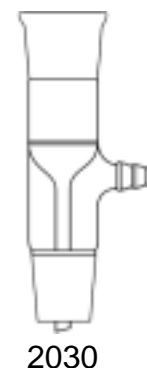

SG & P offers adapters with different lengths and joint combinations than those listed. Call for more information.

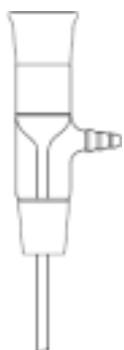

2031

2031 ADAPTER, VACUUM TAKE-OFF, LONG STEM

Standard taper top outer and lower inner joints with sealed in lower tube extending below inner joint. 10mm hose connection.

Part Number	Joint Size
2031-01	14/20
2031-02	24/40
2031-03	29/42



2032

2032 ADAPTER, VACUUM TAKE-OFF, 105°

Standard taper top outer and lower inner joints with sealed in drip tip. 10mm hose connection.

Part Number	Joint Size
2032-01	14/20
2032-02	24/40
2032-03	29/42

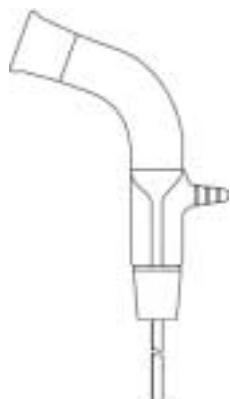

2033

2033 ADAPTER, VACUUM TAKE-OFF, 105°

Standard taper top outer and lower inner joints with sealed in lower tube extending below inner joint. 10mm hose connection.

Part Number	Joint Size
2033-01	14/20
2033-02	24/40
2033-03	29/42

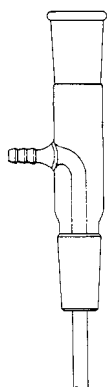

2034

2034 ADAPTER, GAS INLET

Standard taper top outer and lower inner joints with tube extending below inner joint. 10mm hose connection.

Part Number	Joint Size
2034-01	24/40
2034-02	29/42

SG & P offers adapters with different lengths and joint combinations than those listed. Call for more information.

2035 ADAPTER, GAS INLET, STRAIGHT

Standard taper top outer and lower inner joints. 10mm hose connection.

Part Number	Joint Size
2035-01	14/20
2035-02	24/40
2035-03	29/42

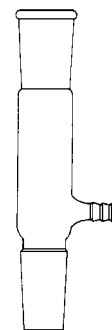

2035

2036 ADAPTER, INERT GAS

Standard taper joint with twin hose connections opposite each other to allow inert gas flow over the top of apparatus. 10mm hose connections.

Part Number	Joint Size
2036-01	14/20
2036-02	24/40
2036-03	29/42

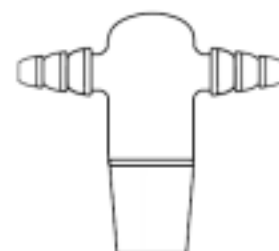

2036

2037 ADAPTER, THERMOMETER, 10° OFFSET

Standard taper inner joint with 10/30 outer joint at top for use with a thermometer.

Part Number	Joint Size
2037-01	24/40
2037-02	29/42

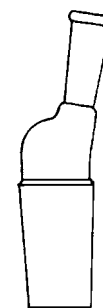

2037

2038 ADAPTER, OFFSET

Standard taper top outer and lower inner joints.

Part Number	Joint Size
2038-01	14/20
2038-02	24/40
2038-03	29/42



2038

SG & P offers adapters with different lengths and joint combinations than those listed. Call for more information.

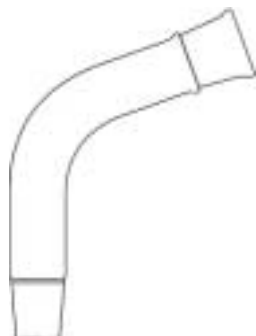

2039

2039 ADAPTER, DISTILLATION, 105°

Standard taper top outer and lower inner joints.

Part Number	Joint Size
2039-01	14/20
2039-02	24/40
2039-03	29/42



2040

2040 ADAPTER, DISTILLATION, 105°

Standard taper top outer and lower inner joints with sealed lower drip tip.

Part Number	Joint Size
2040-01	14/20

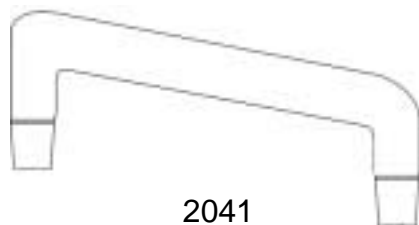

2041

2041 ADAPTER, DISTILLATION, PARALLEL, 75°

Standard taper top inner joints.

Part Number	Joint Size
2041-01	14/20
2041-02	24/40
2041-03	29/42

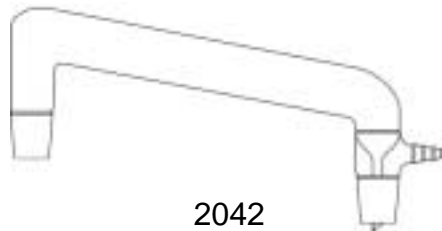

2042

2042 ADAPTER, DISTILLATION, PARALLEL, 75°

Standard taper inner joints with sealed in drip tip and hose connection.

Part Number	Joint Size
2042-01	14/20
2042-02	24/40
2042-03	29/42

SG & P offers adapters with different lengths and joint combinations than those listed. Call for more information.

Call **1-800-880-7722** Toll Free

2043 ADAPTER, DISTILLATION, 105°, JACKETED

Water jacket completely surrounds adapter, for use with highly volatile condensates. 10mm hose connection.

Part Number	Joint Size
2043-01	24/40
2043-02	29/42



2043

2044 ADAPTER, DISTILLATION, 75°, JACKETED

For use as a distilling head to connect top of column with condenser. Standard taper inner joints at bottom and side. Top 10/30 outer joint for use with 75mm immersion thermometer.

Part Number	Joint Size
2044-01	24/40
2044-02	29/42

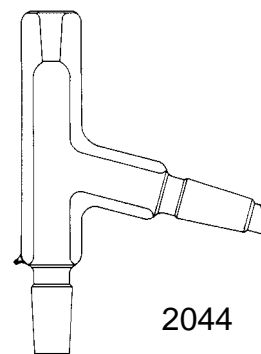

2044

2045 ADAPTER, DISTILLING TRAP, 75°, KJELDAHL

Standard taper inner joint with drip tip. 8mm outlet tube.

Part Number	Joint Size
2045-01	24/40
2045-02	29/42

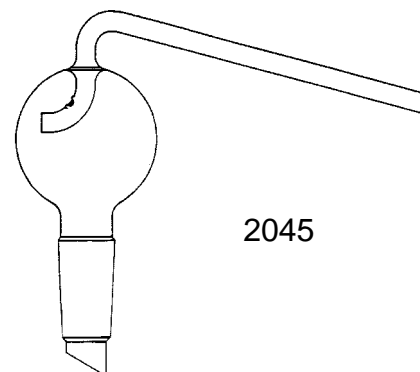

2045

2046 ADAPTER, DISTILLING, 75°

Standard taper inner lower inner joints. 10/18 or 10/30 joint at top for thermometer.

Part Number	Joint Size
2046-01	14/20
2046-02	24/40
2046-03	29/42

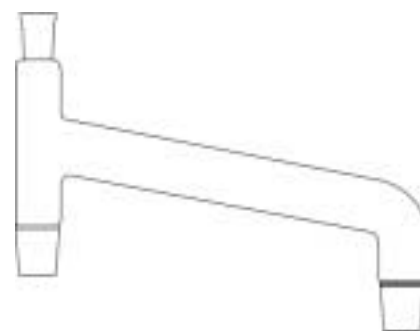

2046

SG & P offers adapters with different lengths and joint combinations than those listed. Call for more information.

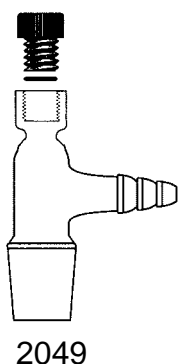

ACE-THREDS

Ace-Threds offer a great grease free, clamp free connection on many types of scientific glassware.

ACE-THRED SIZES

Size	Accepts Tube	O.D.
#7	6-7 mm	1/4"
#11	9-10.5 mm	3/8"
#15	12.5-14 mm	1/2"
#18	16-17 mm	5/8"
#25	24-25 mm	1"
#36	34-35 mm	1 1/2"
#50	47-48 mm	2"
#80	75 mm	3"

2047 ADAPTER, ACE-THRED

Standard taper joint at bottom and Ace-Thred at top. Includes threaded bushing and o-ring.

Part Number	Joint Size	Thread Number
2047-01	14/20	#7
2047-02	24/40	#7
2047-03	29/42	#7
2047-04	24/40	#11
2047-05	29/42	#11

2048 ADAPTER, OFFSET, ACE-THRED

Thermometer adapter with standard taper joint at bottom and top thread offset and angled approximately 10°. Includes threaded bushing and o-ring.

Part Number	Joint Size
2048-01	24/40

2049 ADAPTER, WITH HOSE CONNECTION, ACE-THRED

Standard taper joint at bottom, Ace-Thred at top and hose connection. Includes threaded bushing and o-ring.

Part Number	Joint Size	Thread Number
2049-01	14/20	#7
2049-02	24/40	#7
2049-03	29/42	#7
2049-04	24/40	#11
2049-05	29/42	#11

We can add Ace-Threds to any piece of custom glassware.

2050 ADAPTER, WITH STOPCOCK, ACE-THRED

Standard taper joint at bottom, Ace-Thred at top, with Teflon 2mm bore stopcock and hose connection. Includes threaded bushing and o-ring.

<u>Part Number</u>	<u>Joint Size</u>	<u>Thread Number</u>
2050-01	14/20	#7
2050-02	24/40	#7
2050-03	29/42	#7
2050-04	24/40	#11
2050-05	29/42	#11

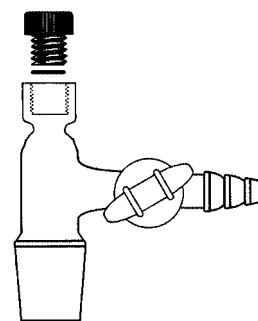

2050

2051 ADAPTER, CLAISEN, ACE-THRED

Top side arm has Ace-Thred for use with adjustable length thermometer. Includes threaded bushing and o-ring.

<u>Part Number</u>	<u>Joint Size</u>	<u>Thread Number</u>
2051-01	24/40	#7

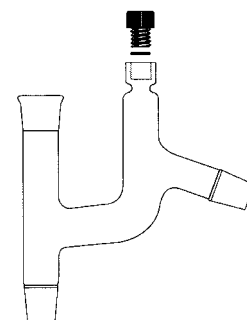

2051

2052 ADAPTER, 75° ANGLE, ACE-THRED

Standard taper inner joints at bottom and side. Ace-Thred at top for use with adjustable length thermometer. Includes threaded bushing and o-ring.

<u>Part Number</u>	<u>Joint Size</u>	<u>Thread Number</u>
2052-01	24/40	#7

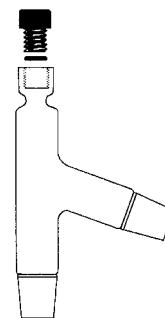

2052

2053 ADAPTER, OFFSET, ACE-THRED

Standard taper inner joint at bottom and offset outer joint. Ace-Thred at top for use with adjustable length thermometer. Includes threaded bushing and o-ring.

<u>Part Number</u>	<u>Joint Size</u>	<u>Thread Number</u>
2053-01	24/40	#7

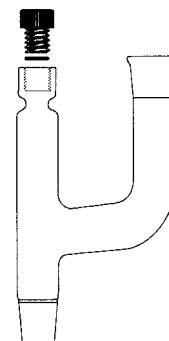

2053

2054 ADAPTER, DISTILLING, ACE-THRED

For connecting distilling column with vertical condenser. Standard taper inner joints at bottom and Ace-Thred at top. Includes threaded bushing and o-ring.

<u>Part Number</u>	<u>Joint Size</u>	<u>Thread Number</u>
2054-01	24/40	#7

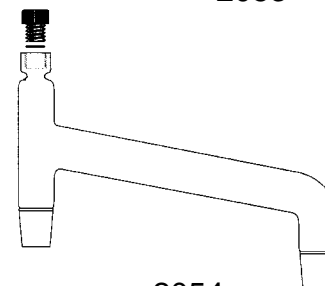

2054

We can add Ace-Threds to any piece of custom glassware.



2100

2100 BEAKER, JACKETED REACTION

Designed for use in a variety of temperature controlled reactions. Jacket has 10mm hose connections. Specify capacity.

<u>Part Number</u>	<u>Capacity ML</u>
2100-01	50
2100-02	100
2100-03	250
2100-04	500
2100-05	1000

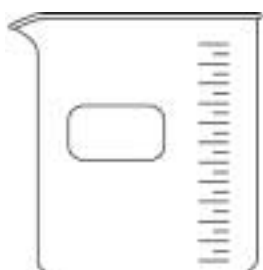

2101

2101 BEAKER, GRIFFIN, LOW FORM

Graduated with pour spout. Specify capacity.

BOTTLES

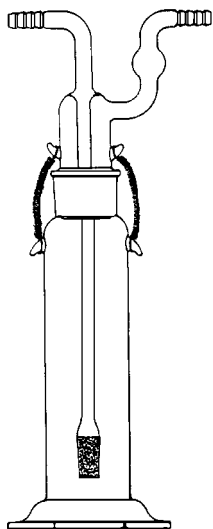

2200

2200 BOTTLE, GAS WASHING, TALL FORM, FRITTED

Standard taper 29/42 joint. Available with coarse or extra coarse fritted cylinder.

Complete Bottles:

<u>Part Number</u>	<u>Capacity ML</u>	<u>Approximate Height MM</u>	<u>Porosity</u>
2200-01	125	290	X-Coarse
2200-02	125	290	Coarse
2200-03	250	305	X-Coarse
2200-04	250	305	Coarse
2200-05	500	380	X-Coarse
2200-06	500	380	Coarse

Replacement Components:

<u>Part Number</u>	<u>Description</u>	<u>Approximate Height MM</u>	<u>Porosity</u>
2200-07	Stopper	125ml	X-Coarse
2200-08	Stopper	125ml	Coarse
2200-09	Stopper	250ml	X-Coarse
2200-10	Stopper	250ml	Coarse
2200-11	Stopper	500ml	X-Coarse
2200-12	Stopper	500ml	Coarse
2200-13	Bottle	125ml	
2200-14	Bottle	250ml	
2200-15	Bottle	500ml	
2200-16	25mm S.S. Springs, Pkg. of 12		

Call **1-800-880-7722** Toll Free

2201 BOTTLE, GAS WASHING, FRITTED

Standard taper 45/50 joint. Available with coarse or extra coarse fritted disc angled 15° for more uniform gas distribution.

Complete Bottles:

<u>Part Number</u>	<u>Capacity ML</u>	<u>Approximate Height MM</u>	<u>Porosity</u>
2201-01	125	290	Coarse
2201-02	125	290	X-Coarse
2201-03	250	305	Coarse
2201-04	250	305	X-Coarse
2201-05	500	380	Coarse
2201-06	500	380	X-Coarse

Replacement Components:

<u>Part Number</u>	<u>Description</u>	<u>Approximate Height MM</u>	<u>Porosity</u>
2201-07	Stopper	125ml	Coarse
2201-08	Stopper	125ml	X-Coarse
2201-09	Stopper	250ml	Coarse
2201-10	Stopper	250ml	X-Coarse
2201-11	Stopper	500ml	Coarse
2201-12	Stopper	500ml	X-Coarse
2201-13	Bottle	125ml	
2201-14	Bottle	250ml	
2201-15	Bottle	500ml	
2201-16	32mm S.S. Springs, Pkg. of 12		

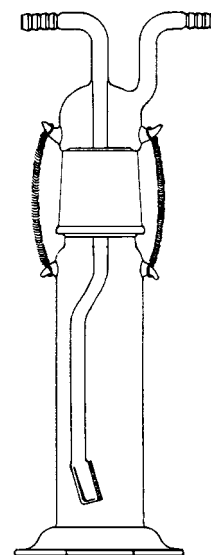

2201

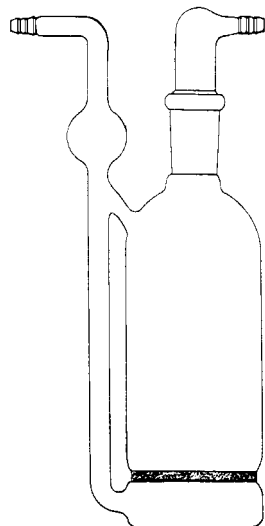

2202

2202 BOTTLE, GAS WASHING FRITTED DISC

Standard taper 24/40 joint. Sealed in 60mm fritted disc. Available with coarse or extra coarse.

Complete Bottles:

<u>Part Number</u>	<u>Capacity ML</u>	<u>Approximate Height MM</u>	<u>Porosity</u>
2202-01	350	250	X-Coarse
2202-02	350	250	Coarse

Replacement Components:

<u>Part Number</u>	<u>Description</u>	<u>Porosity</u>
2202-03	Bottle	X-Coarse
2202-04	Bottle	Coarse
2202-05	24/40 Gas Inlet Adapter	

BUBBLERS

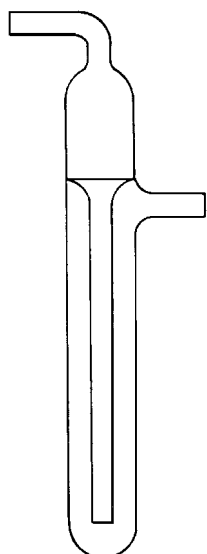

2300

2300 BUBBLER

Provides a vent to the atmosphere. Reservoir head prevents oil from being sucked back into the system. Volume approximately 40ml below side arm.

<u>Part Number</u>
2300-01

We can quote on any type bubbler you may require.

2400 CHROMATOGRAPHY COLUMN

General purpose column. 2mm bore Teflon stopcock.

<u>Part Number</u>	<u>Column I.D. in. (mm)</u>	<u>Effective Length in. (cm)</u>
2400-01	.50 (13)	8 (20.3)
2400-02	.50 (13)	10 (25.4)
2400-03	.50 (13)	12 (30.5)
2400-04	.50 (13)	18 (45.7)
2400-05	.75 (19)	8 (20.3)
2400-06	.75 (19)	10 (25.4)
2400-07	.75 (19)	12 (30.5)
2400-08	.75 (19)	18 (45.7)
2400-09	1.0 (25)	8 (20.3)
2400-10	1.0 (25)	10 (25.4)
2400-11	1.0 (25)	12 (30.5)
2400-12	1.0 (25)	18 (45.7)
2400-13	1.5 (38)	8 (20.3)
2400-14	1.5 (38)	10 (25.4)
2400-15	1.5 (38)	12 (30.5)
2400-16	1.5 (38)	18 (45.7)
2400-17	2.0 (50)	8 (20.3)
2400-18	2.0 (50)	10 (25.4)
2400-19	2.0 (50)	12 (30.5)
2400-20	2.0 (50)	18 (45.7)
2400-21	2.0 (50)	24 (60.1)



2400



2401

2401 CHROMATOGRAPHY COLUMN, WITH FRITTED DISC

General purpose column with sealed in coarse fritted disc. 2mm bore Teflon stopcock.

<u>Part Number</u>	<u>Column I.D. in. (mm)</u>	<u>Effective Length in. (cm)</u>
2401-01	.50 (13)	8 (20.3)
2401-02	.50 (13)	10 (25.4)
2401-03	.50 (13)	12 (30.5)
2401-04	.50 (13)	18 (45.7)
2401-05	.75 (19)	8 (20.3)
2401-06	.75 (19)	10 (25.4)
2401-07	.75 (19)	12 (30.5)
2401-08	.75 (19)	18 (45.7)
2401-09	1.0 (25)	8 (20.3)
2401-10	1.0 (25)	10 (25.4)
2401-11	1.0 (25)	12 (30.5)
2401-12	1.0 (25)	18 (45.7)
2401-13	1.5 (38)	8 (20.3)
2401-14	1.5 (38)	10 (25.4)
2401-15	1.5 (38)	12 (30.5)
2401-16	1.5 (38)	18 (45.7)
2401-17	2.0 (50)	8 (20.3)
2401-18	2.0 (50)	10 (25.4)
2401-19	2.0 (50)	12 (30.5)
2401-20	2.0 (50)	18 (45.7)
2401-21	2.0 (50)	24 (60.1)

2402 CHROMATOGRAPHY COLUMN, STANDARD TAPER JOINT

General purpose column with standard taper outer joint. 2mm bore Teflon stopcock.

Part Number	Column I.D. in. (mm)	Effective Length in. (cm)	Joint Size
2402-01	.50 (13)	8 (20.3)	24/40
2402-02	.50 (13)	10 (25.4)	24/40
2402-03	.50 (13)	12 (30.5)	24/40
2402-04	.50 (13)	18 (45.7)	24/40
2402-05	.75 (19)	8 (20.3)	24/40
2402-06	.75 (19)	10 (25.4)	24/40
2402-07	.75 (19)	12 (30.5)	24/40
2402-08	.75 (19)	18 (45.7)	24/40
2402-09	1.0 (25)	8 (20.3)	24/40
2402-10	1.0 (25)	10 (25.4)	24/40
2402-11	1.0 (25)	12 (30.5)	24/40
2402-12	1.0 (25)	18 (45.7)	24/40
2402-13	1.5 (38)	8 (20.3)	24/40
2402-14	1.5 (38)	10 (25.4)	24/40
2402-15	1.5 (38)	12 (30.5)	24/40
2402-16	1.5 (38)	18 (45.7)	24/40
2402-17	2.0 (50)	8 (20.3)	24/40
2402-18	2.0 (50)	10 (25.4)	24/40
2402-19	2.0 (50)	12 (30.5)	24/40
2402-20	2.0 (50)	18 (45.7)	24/40
2402-21	2.0 (50)	24 (60.1)	24/40



2402



2403

2403 CHROMATOGRAPHY COLUMN, STANDARD TAPER JOINT, WITH FRITTED DISC

General purpose column with sealed in coarse fritted disc and standard taper outer joint. 2mm bore Teflon stopcock.

<u>Part Number</u>	<u>Column I.D. in. (mm)</u>	<u>Effective Length in. (cm)</u>	<u>Joint Size</u>
2403-01	.50 (13)	8 (20.3)	24/40
2403-02	.50 (13)	10 (25.4)	24/40
2403-03	.50 (13)	12 (30.5)	24/40
2403-04	.50 (13)	18 (45.7)	24/40
2403-05	.75 (19)	8 (20.3)	24/40
2403-06	.75 (19)	10 (25.4)	24/40
2403-07	.75 (19)	12 (30.5)	24/40
2403-08	.75 (19)	18 (45.7)	24/40
2403-09	1.0 (25)	8 (20.3)	24/40
2403-10	1.0 (25)	10 (25.4)	24/40
2403-11	1.0 (25)	12 (30.5)	24/40
2403-12	1.0 (25)	18 (45.7)	24/40
2403-13	1.5 (38)	8 (20.3)	24/40
2403-14	1.5 (38)	10 (25.4)	24/40
2403-15	1.5 (38)	12 (30.5)	24/40
2403-16	1.5 (38)	18 (45.7)	24/40
2403-17	2.0 (50)	8 (20.3)	24/40
2403-18	2.0 (50)	10 (25.4)	24/40
2403-19	2.0 (50)	12 (30.5)	24/40
2403-20	2.0 (50)	18 (45.7)	24/40
2403-21	2.0 (50)	24 (60.1)	24/40



2404

2404 CHROMATOGRAPHY RESERVOIR

For use with chromatography columns. 24/40 standard taper top outer and lower inner joints.

<u>Part Number</u>	<u>Capacity ML</u>
2404-01	100
2404-02	250
2404-03	500
2404-04	1000
2404-05	2000
2404-06	3000
2402-07	5000

2405 FLOW CONTROL ADAPTER

24/40 standard taper inner joint. 0-4mm metering plug.

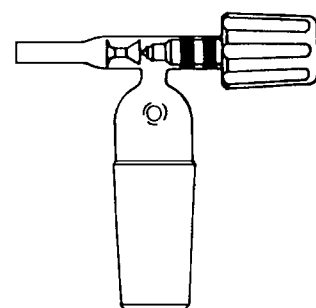

2405

Part
Number
2405-01

2406 CHROMATOGRAPHY COLUMN, STANDARD TAPER JOINT, WITH RESERVOIR

General purpose column with reservoir in capacities shown. Standard taper outer joint. 2mm bore Teflon stopcock.

Part Number	I.D. in.	Effective Length in	Reservoir Capacity ml	Joint Size
2406-01	.50	8	100	24/40
2406-02	.50	10	100	24/40
2406-03	.50	12	250	24/40
2406-04	1.0	8	250	24/40
2406-05	1.0	12	250	24/40
2406-06	1.0	18	500	24/40
2406-07	1.5	8	500	24/40
2406-08	1.5	12	500	24/40
2406-09	1.5	18	500	24/40
2406-10	2.0	8	500	24/40
2406-11	2.0	12	1000	24/40
2406-12	2.0	18	1000	24/40



2406

2407 CHROMATOGRAPHY COLUMN, STANDARD TAPER JOINT WITH RESERVOIR AND FRITTED DISC

General purpose column with reservoir in capacities shown and sealed in coarse fritted disc. Standard taper outer joint. 2mm bore Teflon stopcock.

Part Number	I.D. in.	Effective Length in	Reservoir Capacity ml	Joint Size
2407-01	.50	8	100	24/40
2407-02	.50	10	100	24/40
2407-03	.50	12	250	24/40
2407-04	1.0	8	250	24/40
2407-05	1.0	12	250	24/40
2407-06	1.0	18	500	24/40
2407-07	1.5	8	500	24/40
2407-08	1.5	12	500	24/40
2407-09	1.5	18	500	24/40
2407-10	2.0	8	500	24/40
2407-11	2.0	12	1000	24/40
2407-12	2.0	18	1000	24/40



2407

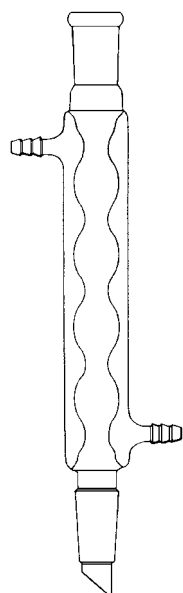

2500

2500 CONDENSER, ALLIHN

Bulb type condenser. Standard taper top outer joint and lower inner joint with drip tip. 10mm hose connections.

<u>Part Number</u>	<u>Jacket Length mm</u>	<u>Joint Size</u>
2500-01	200	24/40
2500-02	250	24/40
2500-03	300	24/40
2500-04	400	24/40
2500-05	500	24/40
2500-06	600	24/40
2500-07	200	29/42
2500-08	250	29/42
2500-09	300	29/42
2500-10	400	29/42
2500-11	500	29/42
2500-12	600	29/42

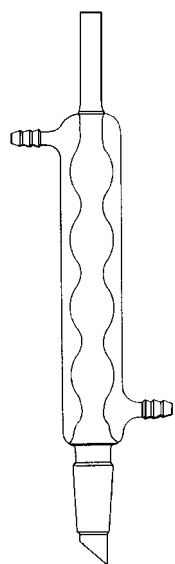

2501

2501 CONDENSER, ALLIHN

Bulb type condenser with plain tubulation at top and standard taper lower inner joint with drip tip. 10mm hose connections.

<u>Part Number</u>	<u>Jacket Length mm</u>	<u>Joint Size</u>
2501-01	120	14/20
2501-02	200	24/40
2501-03	300	24/40
2501-04	400	24/40
2501-05	200	29/42
2501-06	300	29/42
2501-07	400	29/42

2502 CONDENSER, GRAHAM

Standard taper top outer joint and lower inner joint with drip tip. 10mm hose connections.

<u>Part Number</u>	<u>Jacket Length mm</u>	<u>Joint Size</u>
2502-01	200	24/40
2502-02	250	24/40
2502-03	300	24/40
2502-04	400	24/40
2502-05	500	24/40
2502-06	600	24/40
2502-07	200	29/42
2502-08	250	29/42
2502-09	300	29/42
2502-10	400	29/42
2502-11	500	29/42
2502-12	600	29/42

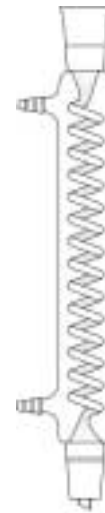

2502

2503 CONDENSER, GRAHAM

Standard taper top outer joint and lower 8mm delivery stem. 10mm hose connections.

<u>Part Number</u>	<u>Jacket Length mm</u>	<u>Joint Size</u>
2503-01	300	24/40

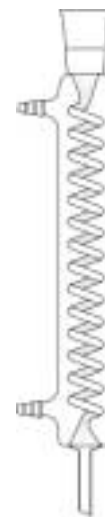

2503

2504 CONDENSER, COILED

Double jacketed with standard taper top outer joint and lower inner joint with drip tip. 10mm hose connections at top opposite each other.

<u>Part Number</u>	<u>Jacket Length mm</u>	<u>Joint Size</u>
2504-01	250	24/40
2504-02	300	24/40
2504-03	400	24/40

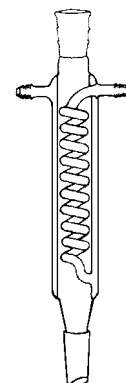

2504

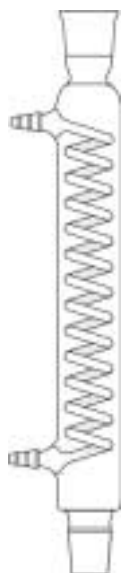

2505

2505 CONDENSER, REFLUX

Standard taper top outer joint and lower inner joint with drip tip. 10mm hose connections.

<u>Part Number</u>	<u>Jacket Length mm</u>	<u>Joint Size</u>
2505-01	200	24/40
2505-02	250	24/40
2505-03	300	24/40
2505-04	400	24/40
2505-05	500	24/40
2505-06	200	29/42
2505-07	250	29/42
2505-08	300	29/42
2505-09	400	29/42
2505-10	500	29/42

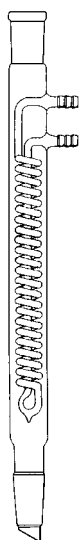

2506

2506 CONDENSER, REFLUX, SPIRAL

Standard taper top outer joint and lower inner joint with drip tip. Both 10mm hose connections same side at top.

<u>Part Number</u>	<u>Jacket Length mm</u>	<u>Joint Size</u>
2506-01	100	14/20
2506-02	150	24/40
2506-03	200	24/40
2506-04	250	24/40
2506-05	300	24/40
2506-06	400	24/40
2506-07	200	29/42
2506-08	250	29/42
2506-09	300	29/42
2506-10	400	29/42

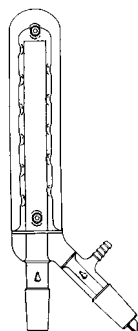

2507

2507 CONDENSER, CONCENTRATOR

Vapors rise to the top of inner tube then travel down and condense. Condensate drains through the side tube. Standard taper inner joints. 10mm hose connection.

<u>Part Number</u>	<u>Inner Tube Height mm</u>	<u>Joint Size</u>
2507-01	200	24/40
2507-02	200	29/42

2508 CONDENSER, FRIEDRICHS

Designed to provide a long vapor path, good heat transfer and anti-flooding characteristics. Standard taper outer joint 15° to the condenser and lower inner joint with drip tip. 10mm hose connections.

<u>Part Number</u>	<u>Joint Size</u>
2508-01	24/40
2508-02	29/42

2509 CONDENSER, FRIEDRICHS

Similar to 2508, but with a hose connection in place of side joint. 10mm hose connections. Primarily used in reflux mode and Soxhlet extractions.

<u>Part Number</u>	<u>Joint Size</u>
2509-01	24/40
2509-02	34/45

2510 CONDENSER, DEWAR

Large opening for dry ice/acetone or liquid nitrogen. Standard taper inner joint with drip tip. 10mm hose connection.

<u>Part Number</u>	<u>Inside Dimensions Depth x I.D. mm</u>	<u>Joint Size</u>
2510-01	200 x 40	24/40
2510-02	250 x 50	24/40
2510-03	350 x 75	24/40
2510-04	200 x 40	29/42
2510-05	250 x 50	29/42
2510-06	350 x 75	29/42

2511 CONDENSER, DEWAR

Large opening dry ice/acetone or liquid nitrogen. Standard taper outer joint at top and lower inner joint with drip tip.

<u>Part Number</u>	<u>Inside Dimensions Depth x I.D. mm</u>	<u>Joint Size</u>
2511-01	90 x 37	14/20
2511-02	90 x 70	14/20
2511-03	120 x 31	14/20
2511-04	200 x 40	24/40
2511-05	250 x 50	24/40
2511-06	350 x 75	24/40
2511-07	200 x 40	29/42
2511-08	250 x 50	29/42
2511-09	350 x 75	29/42

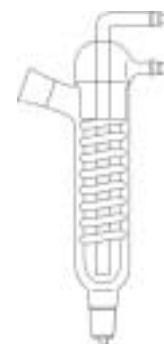

2508

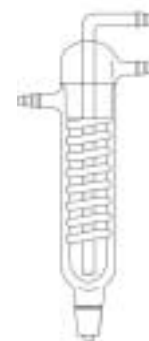

2509



2510

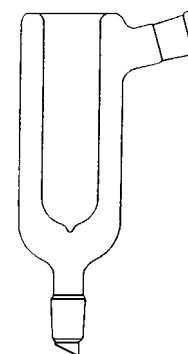

2511



2512

2512 CONDENSER, LIEBIG

Standard taper top outer joint and lower inner joint with drip tip. 10mm hose connections.

<u>Part Number</u>	<u>Jacket Length mm</u>	<u>Joint Size</u>
2512-01	110	14/20
2512-02	200	24/40
2512-03	250	24/40
2512-04	300	24/40
2512-05	400	24/40
2512-06	500	24/40
2512-07	600	24/40
2512-08	200	29/42
2512-09	250	29/42
2512-10	300	29/42
2512-11	400	29/42
2512-12	500	29/42
2512-13	600	29/42



2513

2513 CONDENSER, LIEBIG, JACKETED

Standard taper top outer joint and lower inner joint with drip tip. Both outer and inner joints water jacketed. 10mm hose connections.

<u>Part Number</u>	<u>Jacket Length mm</u>	<u>Joint Size</u>
2513-01	200	24/40
2513-02	300	24/40
2513-03	400	24/40
2513-04	200	29/42
2513-05	300	29/42
2513-06	400	29/42

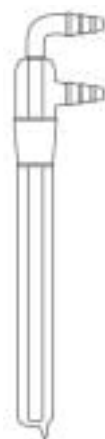

2514

2514 CONDENSER, COLD FINGER

Standard taper inner joint and sealed lower drip tip. 10mm hose connection.

<u>Part Number</u>	<u>Length Below Joint mm</u>	<u>Joint Size</u>
2514-01	100	14/20
2514-02	150	24/40
2514-03	200	24/40
2514-04	250	24/40
2514-05	150	29/42
2514-06	200	29/42
2514-07	250	29/42

2600 DISTILLING COLUMN, HEMPLE

Standard taper top outer and lower inner joints. Indentations to support packing. Column length listed refers to the length between the indentations to the bottom of the top outer joint.

Part Number	Joint Size	Column I.D. mm	Column Length mm
2600-01	14/20	10.0	130
2600-02	14/20	10.0	250
2600-03	24/40	12.5	300
2600-04	24/40	19.0	300
2600-05	24/40	25.0	300
2600-06	24/40	12.5	400
2600-07	24/40	19.0	400
2600-08	24/40	25.0	400
2600-09	24/40	12.5	500
2600-10	24/40	19.0	500
2600-11	24/40	25.0	500
2600-12	29/42	12.5	300
2600-13	29/42	19.0	300
2600-14	29/42	25.0	300
2600-15	29/42	12.5	400
2600-16	29/42	19.0	400
2600-17	29/42	25.0	400
2600-18	29/42	12.5	500
2600-19	29/42	19.0	500
2600-20	29/42	25.0	500

2601 DISTILLING COLUMN, HEMPLE, VACUUM JACKETED

Same as 2600, except with vacuum jacket. All sizes have 10mm ID.

Part Number	Joint Size	Column Length mm	Overall Length mm
2601-01	14/20	130	215
2601-02	24/40	250	375

2602 DISTILLING COLUMN, WATER JACKETED

Standard taper top outer and lower inner joints. Indentations to support packing. Column length listed refers to the length between the indentations to the bottom of the top outer joint. Jacket allows the column to be used as a condenser. 10mm hose connections. All sizes have 10mm ID.

Part Number	Joint Size	Column Length mm	Overall Length mm
2602-01	14/20	110	180
2602-02	14/20	200	270
2602-03	24/40	200	305



2600



2601



2602



2603

2603 DISTILLING COLUMN, VIGREUX

Standard taper top outer and lower inner joints. Indentations run entire length of the column. Column length listed refers to the length from the lowest to the highest indentations.

<u>Part Number</u>	<u>Joint Size</u>	<u>Column Length mm</u>
2603-01	14/20	100
2603-02	14/20	130
2603-03	14/20	170
2603-04	24/40	150
2603-05	24/40	200
2603-06	24/40	300
2603-07	24/40	450
2603-08	24/40	600
2603-09	29/42	150
2603-10	29/42	200
2603-11	29/42	300
2603-12	29/42	450
2603-13	29/42	600



2604

2604 DISTILLING COLUMN, SNYDER

Standard taper top outer and lower inner joints. Floating ball valves for improved vapor-liquid contact. Each section is approximately 50mm long.

<u>Part Number</u>	<u>Joint Size</u>	<u>Column Length mm</u>
2604-01	24/40	150
2604-02	24/40	300
2604-03	24/40	400
2604-04	24/40	600

2605 DISTILLING COLUMN, PERFORATED PLATE, OLDERSHAW

Standard taper top outer and lower inner joints. Sealed in perforated plates with weirs.

<u>Part Number</u>	<u>Plate Diameter mm</u>	<u>Number of Plates</u>	<u>Joint Size</u>
2605-01	19	5	29/42
2605-02	19	10	29/42
2605-03	19	15	29/42
2605-04	19	20	29/42
2605-05	19	30	29/42
2605-06	28	5	29/42
2605-07	28	10	29/42
2605-08	28	15	29/42
2605-09	28	20	29/42
2605-10	28	30	29/42
2605-11	50	5	55/50
2605-12	50	10	55/50
2605-13	50	15	55/50
2605-14	50	20	55/50
2605-15	50	30	55/50

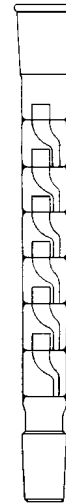

2605

2606 DISTILLING COLUMN, PERFORATED PLATE, OLDERSHAW, JACKETED, SILVERED

Same as 2605 but with the addition of a vacuum jacket, internal bellows and silvered with two 1/4" wide viewing strips.

<u>Part Number</u>	<u>Plate Diameter mm</u>	<u>Number of Plates</u>	<u>Joint Size</u>
2606-01	19	5	29/42
2606-02	19	10	29/42
2606-03	19	15	29/42
2606-04	19	20	29/42
2606-05	19	30	29/42
2606-06	28	5	29/42
2606-07	28	10	29/42
2606-08	28	15	29/42
2606-09	28	20	29/42
2606-10	28	30	29/42
2606-11	50	5	55/50
2606-12	50	10	55/50
2606-13	50	15	55/50
2606-14	50	20	55/50
2606-15	50	30	55/50

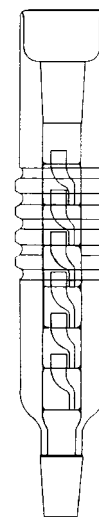

2606

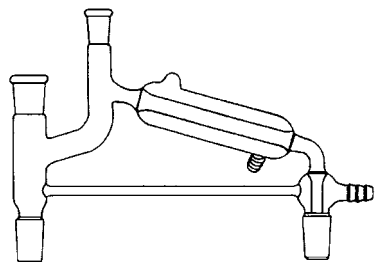

2700

2700 DISTILLING HEAD

Claisen adapter sealed to a Liebig style condenser and a vacuum adapter. All joint same size with the exception of the Claisen sidearm which is 10/30 for an immersion thermometer.

<u>Part Number</u>	<u>Joint Size</u>
2700-01	14/20
2700-02	24/40

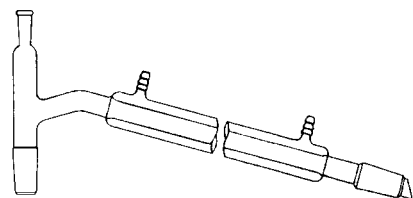

2701

2701 DISTILLING HEAD

Condenser jacket sealed to adapter sidearm at 75° angle.

<u>Part Number</u>	<u>Joint Size</u>	<u>Condenser Length mm</u>
2701-01	14/20	110
2701-02	14/20	200
2701-03	24/40	250
2701-04	29/42	250

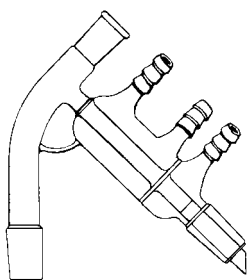

Without Vigreux Indentations:

2702

2702 DISTILLING HEAD, SHORT PATH

For use with small quantities where hold up between flask and receiver must be minimized. Top thermometer joint 10/30. Available with or without Vigreux indentations.

Without Vigreux Indentations:

<u>Part Number</u>	<u>Lower Inner Joint Size</u>
2702-01	14/20
2702-02	24/40
2702-03	29/42

With Vigreux Indentations:

<u>Part Number</u>	<u>Lower Inner Joint Size</u>
2702-04	14/20
2702-05	24/40
2702-06	29/42

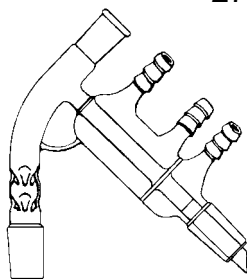

With Vigreux Indentations

2703 DISTILLING HEAD, VIGREUX

Claisen sealed to Vigreux column. 10/30 top joint for immersion thermometer.

Part Number	Joint Size	Column Height mm
2703-01	14/20	100
2703-02	14/20	200
2703-03	24/40	200
2703-04	24/40	250
2703-05	24/40	300
2703-06	29/42	200
2703-07	29/42	250
2703-08	29/42	300

2704 DISTILLING HEAD, VIGREUX, JACKETED

Same as 2703, but with vacuum jacket.

Part Number	Joint Size	Column Height mm
2704-01	14/20	100
2704-02	14/20	200

2705 DISTILLATION HEAD, VIGREUX, JACKETED, MICRO

Distillation head with a condenser sealed to a jacketed Vigreux distilling column. 10/30 joint at top of column for thermometer. 14/20 lower inner joint.

Part Number	Joint Size	Column Height mm
2705-01	14/20	190

2706 DISTILLATION HEAD, VIGREUX, JACKETED, MICRO

Jacketed Vigreux distillation head with two 10/30 joints for immersion thermometers. Condenser is braced for strength.

Part Number	Joint Size	Column Height mm
2706-01	14/20	215

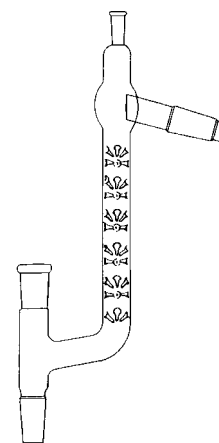

2703

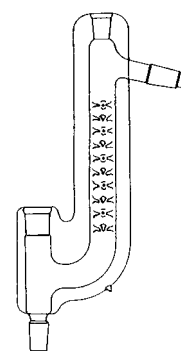

2704

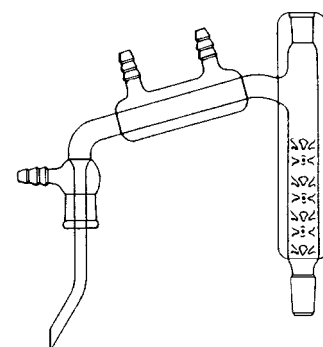

2705

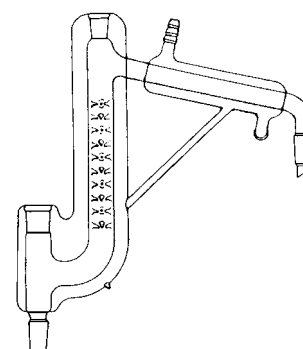

2706

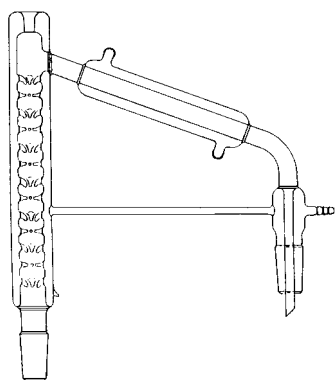

2707

2707 DISTILLATION HEAD, VIGREUX, JACKETED

Vacuum jacketed Vigreux distillation head with sealed on condenser and vacuum adapter braced for strength. Top outer joint 10/30 for immersion thermometer.

<u>Part Number</u>	<u>Joint Size</u>	<u>Column Height mm</u>
2707-01	14/20	100
2707-02	14/20	150
2707-03	24/40	200
2707-04	24/40	300
2707-05	29/42	200
2707-06	29/42	300

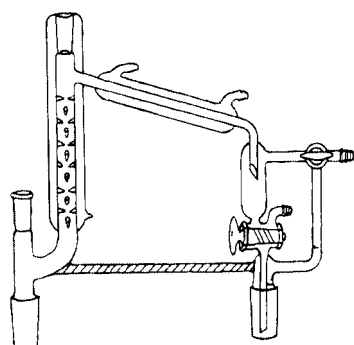

2708

2708 DISTILLING APPARATUS

A compact unit for distilling small quantities in a vacuum. 24/40 lower inner joints and 10/30 outer joint at top of column for thermometer.

<u>Part Number</u>	<u>Column Height mm</u>
2708-01	220

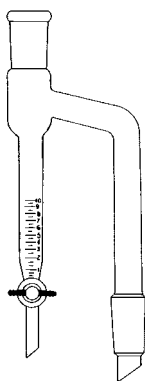

2800

2800 DISTILLING RECEIVER, MOISTURE TEST, BARRETT

Used for the determination of water in petroleum or bituminous products. 2mm Teflon stopcock.

<u>Part Number</u>	<u>Joint Size</u>	<u>Capacity mL</u>
2800-01	14/20	2
2800-02	14/20	5
2800-03	14/20	10
2800-04	24/40	10
2800-05	24/40	20
2800-06	29/42	10
2800-07	29/42	20

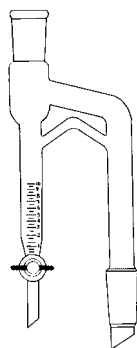

2801

2801 DISTILLING RECEIVER, MOISTURE TEST, BARRETT

Same as 2800, but with the addition of an overflow tube. 2mm Teflon stopcock.

<u>Part Number</u>	<u>Joint Size</u>	<u>Capacity mL</u>
2801-01	24/40	10
2801-02	24/40	20

2802 DISTILLING RECEIVER, MOISTURE TEST, DEAN STARK

Used for determining the water content of various materials.

Part Number	Joint Size	Capacity mL
2802-01	14/20	10
2802-02	14/20	25
2802-03	24/40	10
2802-04	24/40	25
2802-05	29/42	10
2802-06	29/42	25

2803 DISTILLING RECEIVER, MOISTURE TEST, DEAN STARK

Same as 2802, but with the addition of an overflow tube.

Part Number	Joint Size	Capacity mL
2803-01	14/20	10
2803-02	14/20	25
2803-03	24/40	10
2803-04	24/40	25

2804 DISTILLING RECEIVER, MOISTURE TEST, MODIFIED DEAN STARK

Same as 2802, but with the addition of a 10/30 outer joint at top of vapor tube for thermometer.

Part Number	Joint Size	Capacity mL
2804-01	24/40	10
2804-02	24/40	25

2805 DISTILLING RECEIVER, MOISTURE TEST

Dean Stark design for solvents that are either lighter or heavier than water. Three-way Teflon stopcock. 10/30 outer joint on top of vapor tube for thermometer.

Part Number	Joint Size	Capacity mL
2805-01	14/20	5
2805-02	24/40	20
2805-03	29/42	20

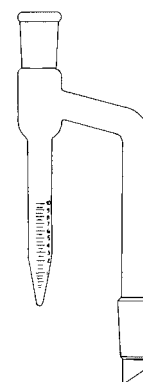

2802

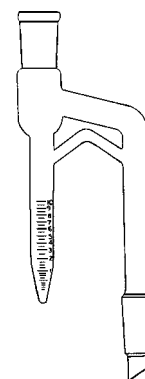

2803

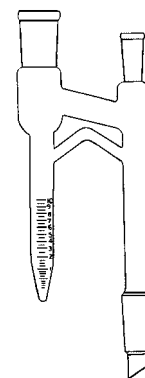

2804

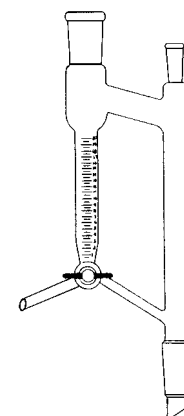

2805

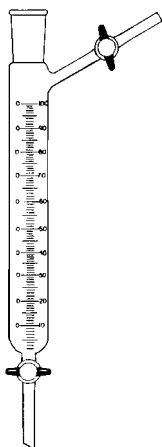

2806

2806 DISTILLING RECEIVER, VACUUM, GRADUATED

Distillation receiver with plain delivery tube. 2mm bore Teflon stopcock.

Part Number	Joint Size	Capacity mL	Subdivisions mL
2806-01	24/40	50	1.0
2806-02	24/40	100	1.0
2806-03	24/40	250	2.0
2806-04	29/42	50	1.0
2806-05	29/42	100	1.0
2806-06	29/42	250	2.0

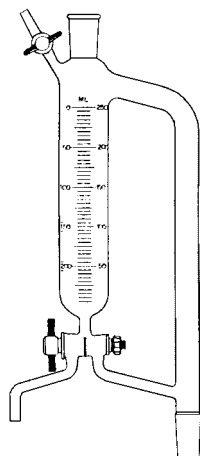

2807

2807 DISTILLING RECEIVER, SOLVENT RECOVERY, GRADUATED

Distillation receiver with a 4mm three way Teflon stopcock. Upper sampling port has 2mm Teflon stopcock.

Part Number	Joint Size	Capacity mL	Subdivisions mL
2807-01	24/40	250	5.0
2807-02	24/40	500	5.0
2807-03	29/42	250	5.0
2807-04	29/42	500	5.0

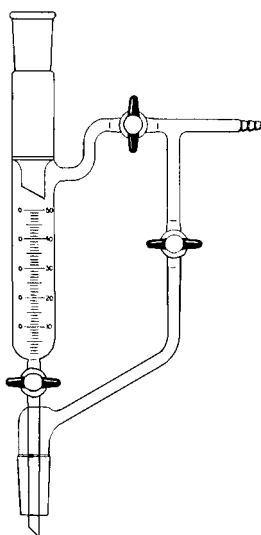

2808

2808 DISTILLING RECEIVER, VACUUM, GRADUATED

Distilling receiver with stopcocks positioned to allow removal of distillate without interrupting the distillation process. 2mm bore Teflon stopcock on the 50 and 100ml sizes and 4mm on the 250ml size.

Part Number	Joint Size	Capacity mL	Subdivisions mL
2808-01	24/40	50	1.0
2808-02	24/40	100	1.0
2808-03	24/40	250	2.0
2808-04	29/42	50	1.0
2808-05	29/42	100	1.0
2808-06	29/42	250	2.0

2809 DISTILLING RECEIVER, VACUUM, GRADUATED

Same as 2808, but with top outer joint at a 105° angle.

Part Number	Joint Size	Capacity mL	Subdivisions mL
2809-01	24/40	50	1.0
2809-02	24/40	100	1.0
2809-03	24/40	250	2.0
2809-04	29/42	50	1.0
2809-05	29/42	100	1.0
2809-06	29/42	250	2.0

2810 DISTILLING RECEIVER

Rotating distillation receiver allow four flasks to be progressively filled. Complete setup includes vacuum adapter, distribution adapter, four receiving flasks and ten stainless steel springs.

Part Number	Joint Size	Receiver Flask Capacity mL
2810-01	14/20	15
2810-02	24/40	50

Replacement Parts Components for 14/20 size:

2810-03	Vacuum Adapter Only, 14/20
2810-04	Distribution Adapter Only, 14/20
2810-05	Receiving Flasks, 15 ml, 14/20
2810-06	S.S. Springs, 6.35 mm, Pkg. of 10

Replacement Parts Components for 24/40 size:

2810-07	Vacuum Adapter Only, 24/40
2810-08	Distribution Adapter Only, 24/40
2810-09	Receiving Flasks, 50 ml, 24/40
2810-10	S.S. Springs, 25 mm, Pkg. of 10

2811 DISTILLING RECEIVER

Same as 2810, but with top outer joint at a 105° angle. See 2810 for replacement parts.

Part Number	Joint Size	Receiver Flask Capacity mL
2811-01	14/20	15
2811-02	24/40	50

2812 DISTILLING RECEIVER

Same as 2810, but with the addition of a 2mm bore Teflon stopcock for vacuum control. See 2810 for replacement parts.

Part Number	Joint Size	Receiver Flask Capacity mL
2812-01	24/40	50

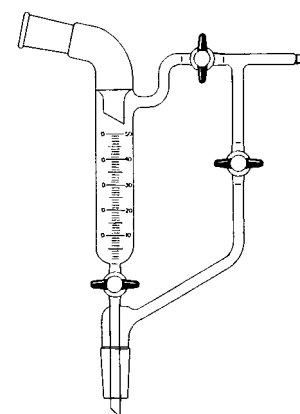

2809

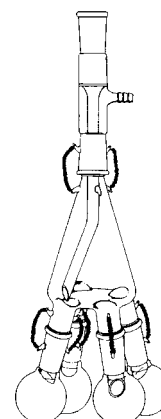

2810

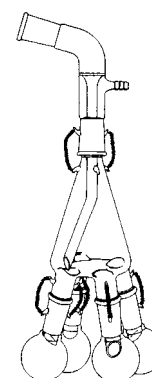

2811

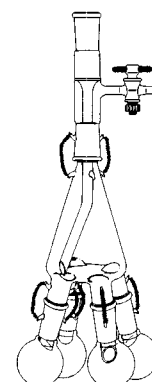

2812

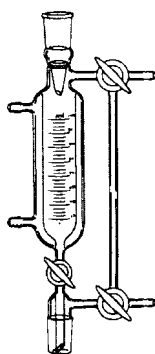

2813

2813 DISTILLING RECEIVER, JACKETED

Jacketed receiver with vacuum manifold for removal of sample during operation without disturbing the system. Stopcocks on manifold are 4 mm bore, receiver stopcock is 3mm.

Part Number	Joint Size	Capacity mL	Subdivisions mL
2813-01	24/40	250	5
2813-02	24/40	500	5

EVAPORATOR CONDENSERS

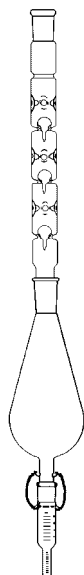

2900

2900 KUDERNA-DANISH CONCENTRATOR

Used in the concentration of trace amounts of sample dissolved in organic solvents. Setup includes a 300mm Snyder column, Kuderna-Danish style flask and graduated concentrator tube. If ordered with hooks, setup is supplied with two springs and one #24 Keck clip. If ordered without hooks, set is supplied with one #19 and one #24 Keck clip.

Part Number	Flask Capacity mL	Lower Tube Capacity mL
2900-01	250	10
2900-02	500	10
2900-03	1000	25

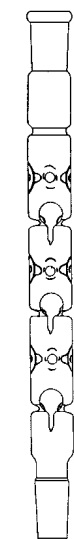

2604

2604 SNYDER DISTILLATION COLUMN

Standard taper 24/40 top outer and lower inner joints. Floating ball valves for improved vapor-liquid contact.

Part Number	Joint Size	Column Length mm
2604-02	24/40	300

2901 SNYDER DISTILLATION COLUMN, ECONOMY

Same as 2604, but without the top 24/40 outer joint.

<u>Part Number</u>	<u>Column Height mL</u>
2901-01	300



2901

2902 KUDERNA-DANISH FLASK

Standard taper 24/40 top outer joint and 19/22 lower inner joint. Available with or without hooks.

<u>Part Number</u>	<u>Flask Capacity mL</u>
2902-01	125
2902-02	250
2902-03	500
2902-04	1000

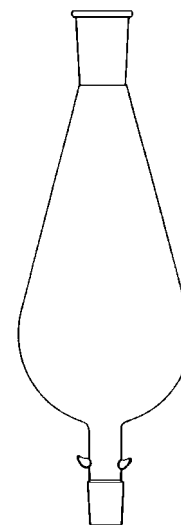

2902

2903 CONCENTRATOR TUBE, GRADUATED

Four use with Kuderna-Danish evaporative setups. Graduated from 0-1 in 0.1 mL subdivisions and 2-10 in 1.0 mL subdivisions. Available with or without hooks.

<u>Part Number</u>	<u>Joint Size</u>	<u>Capacity mL</u>	<u>Subdivisions mL</u>
2903-01	19/22	10	0 to 1mL in 0.1 2 to 10mL in 1.0



2903

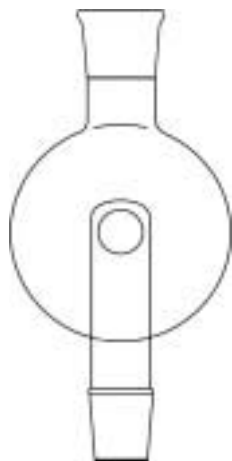

3000

3000 ROTARY EVAPORATOR, ANTI-SPLASH TRAP

Designed to prevent carry-over from foaming or bumping. Standard taper 24/40 top joint. Lower joint sizes listed.

<u>Part Number</u>	<u>Capacity mL</u>	<u>Lower inner Joint Size</u>
3000-01	100	14/20
3000-02	100	24/40
3000-03	250	14/20
3000-04	250	24/40
3000-05	250	29/42
3000-06	500	14/20
3000-07	500	24/40
3000-08	500	29/42
3000-09	1000	24/40
3000-10	1000	29/42

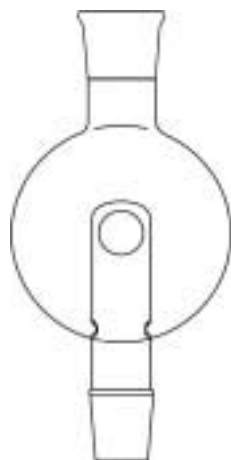

3001

3001 ROTARY EVAPORATOR, ANTI-SPLASH TRAP, MODIFIED

Same as 3000, but with the addition of two drain holes at the base of the inner tube to allow solvent to drain back into evaporator flask.

<u>Part Number</u>	<u>Capacity mL</u>	<u>Lower inner Joint Size</u>
3001-01	100	14/20
3001-02	100	24/40
3001-03	250	14/20
3001-04	250	24/40
3001-05	250	29/42
3001-06	500	24/40
3001-07	500	29/42
3001-08	1000	24/40
3001-09	1000	29/42



3002

3002 ROTARY EVAPORATOR, ANTI-SPLASH TRAP, FRITTED

Extra coarse fritted disc between the top 24/40 joint and lower inner joint.

<u>Part Number</u>	<u>Lower inner Joint Size</u>
3002-01	14/20
3002-02	24/40
3002-03	29/42

3100 EXTRACTOR, LIQUID/LIQUID, CONTINUOUS

Designed for EPA priority pollutant analysis. Accommodates 1 liter sample plus approximately 200mL of extracting solvent. Standard taper 24/40 inner joint on the uptake tube.

Part Number	Top Outer Joint
3100-01	24/40
3100-02	45/50

3101 EXTRACTOR, LIQUID/LIQUID, CONTINUOUS

Same as 3100, but with the addition of a 4mm Teflon stopcock in the return tube.

Part Number	Top Outer Joint
3101-01	24/40
3101-02	45/50

3102 EXTRACTOR, LIQUID/LIQUID, CONTINUOUS

Similar to 3100, but with the return tube sealed into the round bottom.

Part Number	Top Outer Joint
3102-01	24/40
3102-02	45/50

3103 EXTRACTOR, ACCESSORY, ALLIHN CONDENSER

For use with 3100, 3101, and 3102 extractors.

Part Number	Joint Size
3103-01	24/40
3103-02	45/50

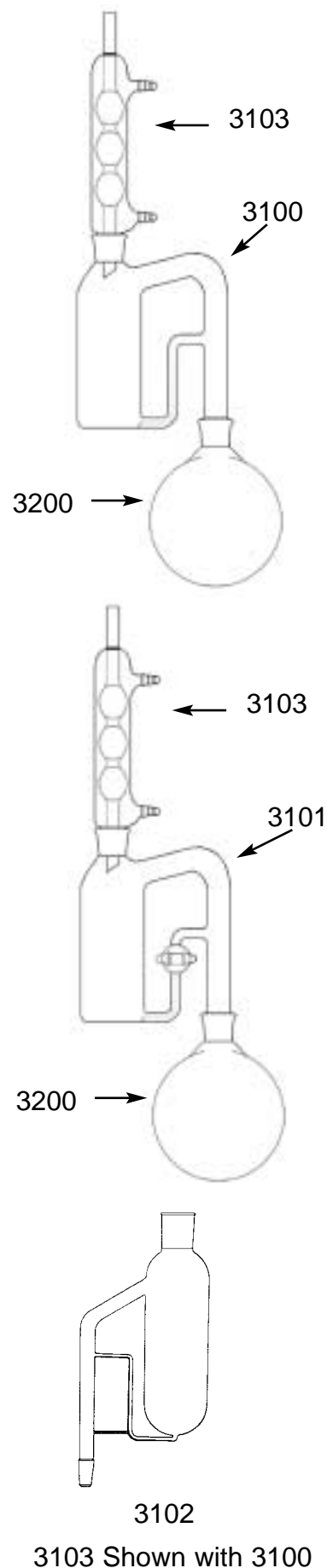



3200 shown
with 3100



3104

3200 EXTRACTOR, ACCESSORY, ROUND BOTTOM FLASK

For use with 3100, 3101, 3102 extractors. 1000mL round bottom flask with 24/40 joint.

<u>Part Number</u>	<u>Joint Size</u>	<u>Capacity mL</u>
3200-25	24/40	1000

3104 EXTRACTION APPARATUS, SOXHLET

Apparatus includes Allihn condenser, extractor and choice of flat or round bottom flask.

<u>Specifications</u>	<u>Small</u>	<u>Medium</u>
Extractor Top Joint	34/45	45/50
Extractor I.D. (mm)	30	38
Extractor Capacity (mL)	50	85
Extractor Lower Joint	24/40	24/40
Flask Capacity (mL)	125	250

Complete Apparatus

<u>Part Number</u>	<u>Size</u>
3104-01	Small
3104-02	Medium
3104-03	Large

Individual Components

<u>Part Number</u>	<u>Description</u>	<u>Size</u>
3104-04	Condenser	Small
3104-05	Condenser	Medium
3104-06	Condenser	Large
3104-07	Extractor	Small
3104-08	Extractor	Medium
3104-09	Extractor	Large
3200-11	Flask, 125mL	Round Bottom
3200-18	Flask, 250mL	Round Bottom
3200-20	Flask, 300mL	Round Bottom
3202-02	Flask, 125mL	Flat Bottom
3202-03	Flask, 250mL	Flat Bottom
3202-05	Flask, 300mL	Flat Bottom

3105 EXTRACTION THIMBLE, GLASS

For use with 3104 extractor.

<u>Part Number</u>	<u>Fits Extractor Size</u>	<u>O.D. x Height mm</u>	<u>Porosity</u>
3105-01	Small	25 x 85	Coarse
3105-02	Small	25 x 85	X-Coarse
3105-03	Medium	35 x 90	Coarse
3105-04	Medium	35 x 90	X-Coarse
3105-05	Large	45 x 130	Coarse
3105-06	Large	45 x 130	X-Coarse



3105

3200 FLASK, ROUND BOTTOM

Single neck, with standard taper outer joint.



3200

<u>Part Number</u>	<u>Joint Size</u>	<u>Capacity mL</u>
3200-01	14/20	5
3200-02	14/20	10
3200-03	14/20	15
3200-04	14/20	25
3200-05	14/20	50
3200-06	24/40	50
3200-07	29/42	50
3200-08	14/20	100
3290-09	24/40	100
3200-10	29/42	100
3200-11	24/40	125
3200-12	29/42	125
3200-13	24/40	150
3200-14	29/42	150
3200-15	24/40	200
3200-16	29/42	200
3200-17	14/20	250
3200-18	24/40	250
3200-19	29/42	250
3200-20	24/40	300
3200-21	29/42	300
3200-22	14/20	500
3200-23	24/40	500
3200-24	29/42	500
3200-25	24/40	1000
3200-26	29/42	1000
3200-27	45/50	1000
3200-28	24/40	2000
3200-29	29/26	2000
3200-30	29/42	2000
3200-31	45/50	2000

3201 FLASK, ROUND BOTTOM, LONG NECK

Single long neck, with standard taper outer joint.

<u>Part Number</u>	<u>Joint Size</u>	<u>Capacity mL</u>
3201-01	14/20	10
3201-02	14/20	25
3201-03	14/20	50
3201-04	24/40	50
3201-05	29/42	50
3201-06	14/20	100
3201-07	24/40	100
3201-08	29/42	100
3201-09	24/40	125
3201-10	29/42	125
3201-11	24/40	150
3201-12	29/42	150
3201-13	24/40	200
3201-14	29/42	200
3201-15	24/40	250
3201-16	29/42	250
3201-17	24/40	300
3201-18	29/42	300
3201-19	24/40	500
3201-20	29/42	500
3201-21	24/40	1000
3201-22	29/42	1000
3201-23	24/40	2000
3201-24	29/42	2000
3201-25	24/40	3000
3201-26	29/42	3000
3201-27	24/40	5000
3201-28	29/42	5000



3201

3202 FLASK, FLAT BOTTOM

Single neck, with standard taper outer joint.



3202

<u>Part Number</u>	<u>Joint Size</u>	<u>Capacity mL</u>
3202-01	24/40	50
3202-02	24/40	125
3202-03	24/40	250
3202-04	29/42	250
3202-05	24/40	300
3202-06	29/42	300
3202-07	24/40	500
3202-08	29/42	500
3292-09	24/40	1000
3202-10	29/42	1000
3202-11	45/50	1000
3202-12	24/40	2000
3202-13	29/42	2000
3202-14	45/50	2000
3202-15	24/40	6000
3202-16	29/42	6000
3202-17	45/50	6000

3203 FLASK, FLAT BOTTOM, LONG NECK

Single long neck, with standard taper outer joint.

Part Number	Joint Size	Capacity mL
3203-01	24/40	50
3203-02	24/40	125
3203-03	24/40	250
3203-04	29/42	250
3203-05	24/40	500
3203-06	29/42	500
3203-07	24/40	1000
3203-08	29/42	1000
3203-09	45/50	1000
3203-10	24/40	2000
3203-11	29/42	2000
3203-12	45/50	2000
3203-13	24/40	6000
3203-14	29/42	6000
3203-15	45/50	6000

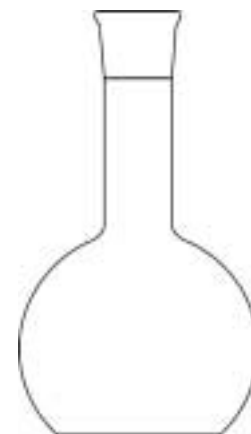

3203

3204 FLASK, ROUND BOTTOM, 2- NECK

Standard taper outer joints on center and vertical side neck.

Part Number	Center Neck	Side Neck	Capacity mL
3204-01	24/40	24/40	100
3204-02	24/40	24/40	250
3204-03	29/42	24/40	250
3204-04	24/40	24/40	500
3204-05	29/42	24/40	500
3204-06	24/40	24/40	1000
3204-07	29/42	24/40	1000
3204-08	24/40	24/40	2000
3204-09	29/42	24/40	2000
3204-10	45/50	24/40	5000

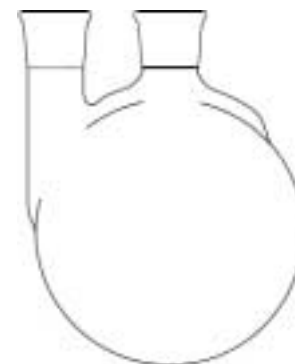

3204

3205 FLASK, ROUND BOTTOM, 2-NECK

Standard taper outer joints on center and angled side neck.



3205

<u>Part Number</u>	<u>Center Neck</u>	<u>Side Neck</u>	<u>Capacity mL</u>
3205-01	14/20	14/20	15
3205-02	14/20	14/20	25
3205-03	14/20	14/20	50
3205-04	14/20	14/20	100
3205-05	24/40	24/40	100
3205-06	24/40	24/40	250
3205-07	29/42	24/40	250
3205-08	14/20	14/20	500
3205-09	24/40	24/40	500
3205-10	29/42	24/40	500
3205-11	24/40	24/40	1000
3205-12	29/42	24/40	1000
3205-13	24/40	24/40	2000
3205-14	29/42	24/40	2000

3206 FLASK, ROUND BOTTOM, 3-NECK

Standard taper outer joints on center and vertical side necks.

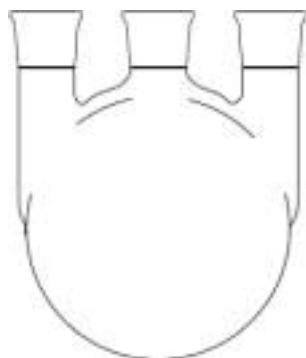

3206

<u>Part Number</u>	<u>Center Neck</u>	<u>Side Necks</u>	<u>Capacity mL</u>
3206-01	24/40	24/40	100
3206-02	24/40	24/40	125
3206-03	24/40	24/40	200
3206-04	24/40	24/40	250
3206-05	29/42	24/40	250
3206-06	29/42	29/42	250
3206-07	24/40	24/40	300
3206-08	24/40	24/40	500
3206-09	29/42	24/40	500
3206-10	29/42	29/42	500
3206-11	34/45	24/40	500
3206-12	34/45	29/42	500
3206-13	45/50	24/40	500
3206-14	24/40	24/40	1000
3206-15	29/42	24/40	1000
3206-16	29/42	29/42	1000
3206-17	34/45	24/40	1000
3206-18	34/45	29/42	1000

3206 CONTINUED

Part Number	Center Neck	Side Necks	Capacity mL
3206-19	45/50	24/40	1000
3206-20	45/50	29/42	1000
3206-21	24/40	24/40	2000
3206-22	29/42	24/40	2000
3206-23	29/42	29/42	2000
3206-24	34/45	24/40	2000
3206-25	34/45	29/42	2000
3206-26	45/50	24/40	2000
3206-27	45/50	29/42	2000
3206-28	24/40	24/40	3000
3206-29	29/42	24/40	3000
3206-30	29/42	29/42	3000
3206-31	45/50	24/40	3000
3206-32	45/50	29/42	3000
3206-33	24/40	24/40	5000
3206-34	29/42	24/40	5000
3206-35	29/42	29/42	5000
3206-36	45/50	24/40	5000
3206-37	45/50	29/42	5000
3206-38	55/50	24/40	5000
3206-39	55/50	29/42	5000
3206-40	29/42	24/40	12000
3206-41	29/42	29/42	12000
3206-42	45/50	24/40	12000
3206-43	45/50	29/42	12000
3206-44	45/50	45/50	12000

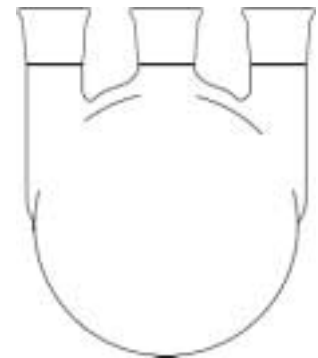

3206
3207 FLASK, ROUND BOTTOM, 3-NECK

Standard taper outer joints on center and 20° angled side necks.

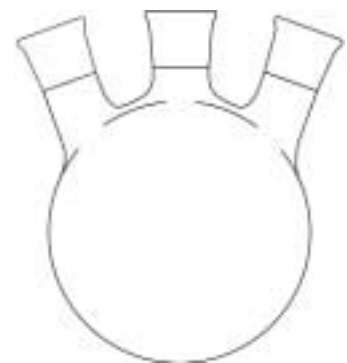
Part Number	Center Neck	Side Necks	Capacity mL
3207-01	24/40	24/40	100
3207-02	24/40	24/40	125
3207-03	24/40	24/40	200
3207-04	24/40	24/40	250
3207-05	29/42	24/40	250
3207-06	29/42	29/42	250
3207-07	24/40	24/40	300
3207-08	24/40	24/40	500
3207-09	29/42	24/40	500
3207-10	29/42	29/42	500

3207
3207 CONTINUED NEXT PAGE

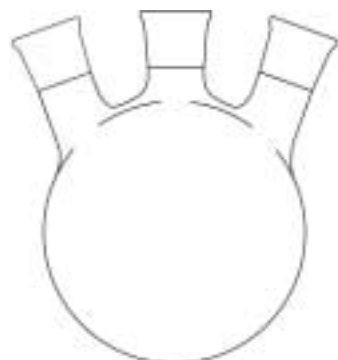
3207 CONTINUED



3207

Part Number	Center Neck	Side Necks	Capacity mL
3207-11	34/45	24/40	500
3207-12	34/45	29/42	500
3207-13	45/50	24/40	500
3207-14	45/50	29/42	500
3207-15	24/40	24/40	1000
3207-16	29/42	24/40	1000
3207-17	29/42	29/42	1000
3207-18	34/45	24/40	1000
3207-19	34/45	29/42	1000
3207-20	45/50	24/40	1000
3207-21	45/50	29/42	1000
3207-22	24/40	24/40	2000
3207-23	29/42	24/40	2000
3207-24	29/42	29/42	2000
3207-25	34/45	24/40	2000
3207-26	34/45	29/42	2000
3207-27	45/50	24/40	2000
3207-28	45/50	29/42	2000
3207-29	24/40	24/40	3000
3207-30	29/42	24/40	3000
3207-31	29/42	29/42	3000
3207-32	34/45	24/40	3000
3207-33	34/45	29/42	3000
3207-34	45/50	24/40	3000
3207-35	45/50	29/42	3000
3207-36	24/40	24/40	5000
3207-37	29/42	24/40	5000
3207-38	29/42	29/42	5000
3207-39	34/45	24/40	5000
3207-40	34/45	29/42	5000
3207-41	45/50	24/40	5000
3207-42	45/50	29/42	5000
3207-43	29/42	24/40	12000
3207-44	29/42	29/42	12000
3207-45	34/45	24/40	12000
3207-46	34/45	29/42	12000
3207-47	45/50	24/40	12000
3207-48	45/50	29/42	12000
3207-49	45/50	45/50	12000

3208 FLASK, ROUND BOTTOM, 3-NECK

Standard taper outer joints on center and 20° angled side necks.

Part Number	Center Neck	Side Necks	Capacity mL
3208-01	14/20	14/20	15
3208-02	14/20	14/20	25
3208-03	19/22	14/20	25
3208-04	14/20	14/20	50
3208-05	14/20	14/20	100
3208-06	14/20	14/20	250
3208-07	14/20	14/20	500

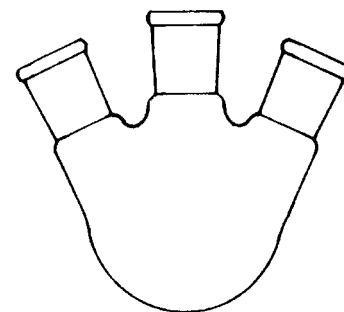

3208

3209 FLASK, ROUND BOTTOM, 4-NECK

Standard taper outer joints on center and vertical side necks.

Part Number	Center Neck	Side Necks	Capacity mL
3209-01	24/40	24/40	250
3209-02	24/40	24/40	500
3209-03	29/42	24/40	500
3209-04	29/42	29/42	500
3209-05	34/45	24/40	500
3209-06	45/50	24/40	500
3209-07	24/40	24/40	1000
3209-08	29/42	24/40	1000
3209-09	29/42	29/42	1000
3209-10	34/45	24/40	1000
3209-11	34/45	29/42	1000
3209-12	45/50	24/40	1000
3209-13	45/50	29/42	1000
3209-14	55/50	24/40	1000
3209-15	24/40	24/40	2000
3209-16	29/42	24/40	2000
3209-17	29/42	29/42	2000
3209-18	34/45	24/40	2000
3209-19	34/45	29/42	2000
3209-20	45/50	24/40	2000
3209-21	45/50	29/42	2000
3209-22	24/40	24/40	3000
3209-23	29/42	24/40	3000
3209-24	29/42	29/42	3000
3209-25	34/45	24/40	3000
3209-26	45/50	24/40	3000

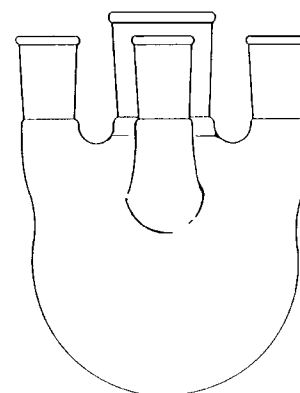

3209

3209 CONTINUED NEXT PAGE

3209 CONTINUED

Part Number	Center Neck	Side Necks	Capacity mL
3209-27	45/50	29/42	3000
3209-28	24/40	24/40	5000
3209-29	29/42	24/40	5000
3209-30	29/42	29/42	5000
3209-31	34/45	24/40	5000
3209-32	34/45	29/42	5000
3209-33	45/50	24/40	5000
3209-34	45/50	29/42	5000
3209-35	55/50	29/42	5000

3210 FLASK, ROUND BOTTOM, 4-NECK

Standard taper outer joints on center and 20° angled side necks.

Part Number	Center Neck	Side Necks	Capacity mL
3210-01	14/20	14/20	25
3210-02	14/20	14/20	50
3210-03	14/20	14/20	100
3210-04	14/20	14/20	250
3210-05	14/20	14/20	500

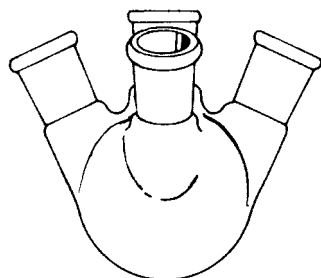

3210

3211 FLASK, ROUND BOTTOM, 4-NECK

Standard taper outer joints on center and 20° angled side necks.

Part Number	Center Neck	Side Necks	Capacity mL
3211-01	24/40	24/40	250
3211-02	24/40	24/40	500
3211-03	29/42	24/40	500
3211-04	29/42	29/42	500
3211-05	34/45	24/40	500
3211-06	45/50	24/40	500
3211-07	24/40	24/40	1000
3211-08	29/42	24/40	1000
3211-09	29/42	29/42	1000
3211-10	34/45	24/40	1000
3211-11	34/45	29/42	1000
3211-12	45/50	24/40	1000
3211-13	45/50	29/42	1000
3211-14	55/50	24/40	1000
3211-15	24/40	24/40	2000
3211-16	29/42	24/40	2000

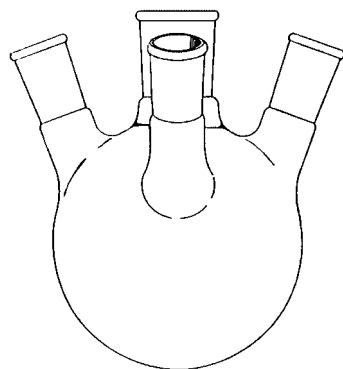

3211

3211 CONTINUED NEXT PAGE

3211 CONTINUED

Part Number	Center Neck	Side Necks	Capacity mL
3211-17	29/42	29/42	2000
3211-18	34/45	24/40	2000
3211-19	34/45	29/42	2000
3211-20	45/50	24/40	2000
3211-21	45/50	29/42	2000
3211-22	24/40	24/40	3000
3211-23	29/42	24/40	3000
3211-24	29/42	29/42	3000
3211-25	34/45	24/40	3000
3211-26	45/50	24/40	3000
3211-27	45/50	29/42	3000
3211-28	24/40	24/40	5000
3211-29	29/42	24/40	5000
3211-30	29/42	29/42	5000
3211-31	34/45	24/40	5000
3211-32	34/45	29/42	5000
3211-33	45/50	24/40	5000
3211-34	45/50	29/42	5000
3211-35	55/50	29/42	5000

3212 FLASK, ROUND BOTTOM, 4-NECK

Three neck flask with standard taper outer joints on center and vertical side necks. The fourth neck is a 10/30 outer joint for use with a thermometer.

Part Number	Center Neck	Side Necks	Capacity mL
3212-01	24/42	24/40	250
3212-02	24/40	24/40	500
3212-03	29/42	24/40	500
3212-04	24/40	24/40	1000
3212-05	29/42	24/40	1000
3212-06	34/45	24/40	1000
3212-07	24/40	24/40	2000
3212-08	29/42	24/40	2000
3212-09	34/45	24/40	2000
3212-10	45/50	24/40	2000
3212-11	24/40	24/40	3000
3212-12	29/42	24/40	3000
3212-13	45/50	24/40	3000
3212-14	24/40	24/40	5000
3212-15	29/42	24/40	5000
3212-16	45/50	24/40	5000

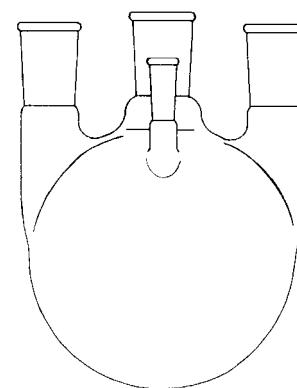
3212



3213

3213 FLASK, ROUND BOTTOM, 5-NECK

Standard taper outer joints on center and vertical side necks.

<u>Part Number</u>	<u>Center Neck</u>	<u>Side Necks</u>	<u>Capacity mL</u>
3213-01	24/40	24/40	1000
3213-02	24/40	24/40	2000
3213-03	29/42	24/40	2000
3213-04	24/40	24/40	3000
3213-05	29/42	24/40	3000
3213-06	24/40	24/40	5000
3213-07	29/42	29/42	5000
3213-08	45/50	24/40	5000
3213-09	45/50	29/42	5000

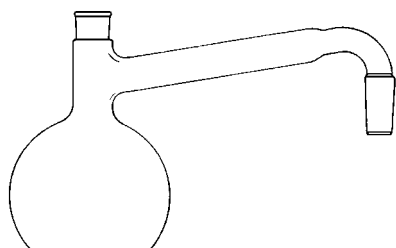

3214

3214 FLASK, DISTILLING, SIDE ARM

1000mL flat bottom flask with 19/38 inner joint on sidearm. Standard taper #27 stopper neck.

<u>Part Number</u>
3214-01

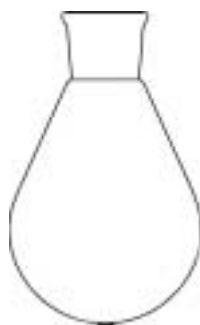

3215

3215 FLASK, RECOVERY

Single neck flask with standard taper outer joint.

<u>Part Number</u>	<u>Joint Size</u>	<u>Capacity mL</u>
3215-01	14/20	10
3215-02	14/20	25
3215-03	14/20	50
3215-04	24/40	50
3215-05	29/42	50
3215-06	14/20	100
3215-07	24/40	100
3215-08	29/42	100
3215-09	14/20	250
3215-10	24/40	250
3215-11	29/42	250
3215-12	24/40	500
3215-13	29/42	500
3215-14	24/40	1000
3215-15	29/42	1000
3215-16	24/40	2000
3215-17	29/42	2000

3216 FLASK, KJELDAHL, LONG NECK

Standard taper outer joint.

Part Number	Joint Size	Capacity mL
3216-01	14/20	30
3216-02	14/20	50
3216-03	14/20	100
3216-04	24/40	100
3216-05	24/40	300
3216-06	24/40	500
3216-07	29/42	500
3216-08	24/40	800
3216-09	29/42	800

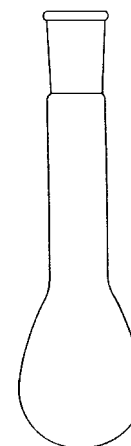

3216

3217 FLASK, ROUND BOTTOM, WITH THERMOWELL

Standard taper outer joint in center and a side well to accept a thermometer.

Part Number	Joint Size	Capacity mL
3217-01	24/40	100
3217-02	24/40	250
3217-03	24/40	500
3217-04	29/42	500
3217-05	24/40	1000
3217-06	29/42	1000
3217-07	24/40	2000
3217-08	29/42	2000

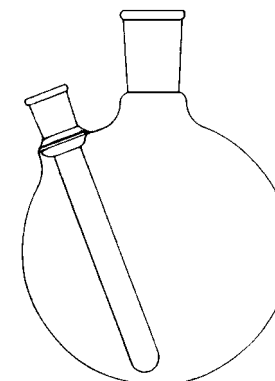

3217

3218 FLASK, ROUND BOTTOM, 3-NECK WITH BOTTOM OUTLET

Standard taper outer joints on center and side necks. 4mm bore Teflon stopcock.

Part Number	Center Neck	Side Necks	Capacity mL
3218-01	24/40	24/40	500
3218-02	29/42	24/40	500
3218-03	24/40	24/40	1000
3218-04	29/42	24/40	1000
3218-05	24/40	24/40	2000
3218-06	29/42	24/40	2000
3218-07	45/50	24/40	2000
3218-08	24/40	24/40	3000
3218-09	29/42	24/40	3000
3218-10	45/50	24/40	3000
3218-11	24/40	24/40	5000
3218-12	29/42	24/40	5000
3218-13	45/50	24/40	5000

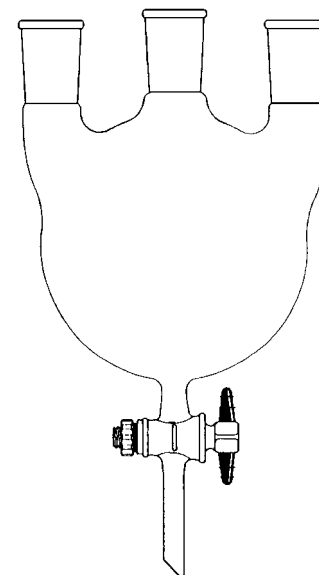

3218

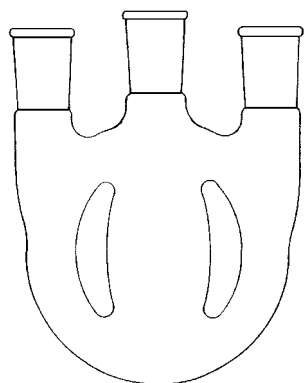

3219

3219 FLASK, ROUND BOTTOM, 3-NECK, MORTON TYPE

Standard taper outer joints on center and side necks. Indentations aid in agitation when stirring. Not recommended for vacuum distillation use.

Part Number	Center Neck	Side Necks	Capacity mL
3219-01	24/40	24/40	500
3219-02	29/42	24/40	500
3219-03	29/42	29/42	500
3219-04	45/50	24/40	500
3219-05	45/50	29/42	500
3219-06	24/40	24/40	1000
3219-07	29/42	24/40	1000
3219-08	29/42	29/42	1000
3219-09	45/50	24/40	1000
3219-10	29/42	29/42	1000
3219-11	24/40	24/40	2000
3219-12	29/42	24/40	2000
3219-13	29/42	29/42	2000
3219-14	45/50	24/40	2000
3219-15	45/50	29/42	2000
3219-16	24/40	24/40	3000
3219-17	29/42	24/40	3000
3219-18	29/42	29/42	3000
3219-19	29/42	24/40	5000
3219-20	29/42	29/42	5000
3219-21	45/50	24/40	5000
3219-22	45/50	29/42	5000

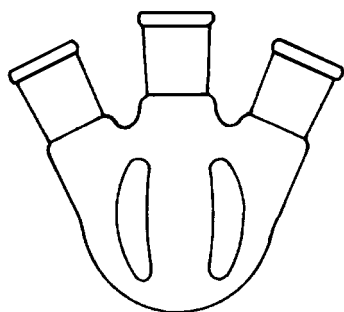

3220

3220 FLASK, ROUND BOTTOM, 3-NECK, MORTON TYPE

Standard taper outer joints on the center and 20° angled side necks. Indentations aid in agitation when stirring. Not recommended for vacuum distillation use.

Part Number	Center Neck	Side Necks	Capacity mL
3220-01	14/20	14/20	50
3220-02	14/20	14/20	100
3220-03	14/20	14/20	250

3221 FLASK, ROUND BOTTOM, REACTION

Standard taper outer joint. 2mm glass stopcock.

Part Number	Joint Size	Capacity mL
3221-01	14/20	50
3221-02	14/20	100
3221-03	24/40	100
3221-04	14/20	250
3221-05	24/40	250
3221-06	24/40	500
3221-07	24/40	1000

3222 FLASK, KJELDAHL, REACTION

Standard taper outer joint. 2mm glass stopcock.

Part Number	Joint Size	Capacity mL	Stopcock Type
3222-01	14/20	10	Glass
3222-02	14/20	25	Glass
3222-03	14/20	50	Glass
3222-04	14/20	100	Glass
3222-05	24/40	100	Glass
3222-06	14/20	250	Glass
3222-07	24/40	250	Glass
3222-08	24/40	500	Glass

3223 FLASK, ROUND BOTTOM, 3-NECK JACKETED WITH LOWER OUTLET

Standard taper outer joints on the center and vertical side necks. Bottom half of flask is jacketed with two hose connections. Available with either glass or Teflon 4mm bore stopcock.

TEFLON STOPCOCK

Part Number	Center Neck	Side Necks	Capacity mL
3223-01	24/40	24/40	500
3223-02	29/42	24/40	500
3223-03	29/42	29/42	500
3223-04	24/40	24/40	1000
3223-05	29/42	24/40	1000
3223-06	29/42	29/42	1000
3223-07	24/40	24/40	2000
3223-08	29/42	24/40	2000
3223-09	29/42	29/42	2000
3223-10	29/42	24/40	3000
3223-11	29/42	29/42	3000
3223-12	45/50	24/40	3000
3223-13	45/50	29/42	3000

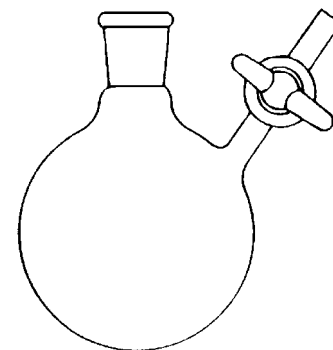

3221

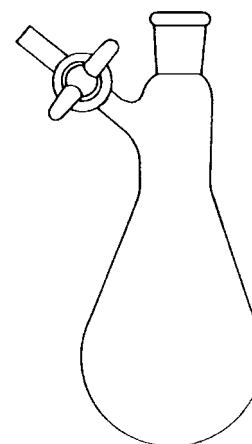

3222

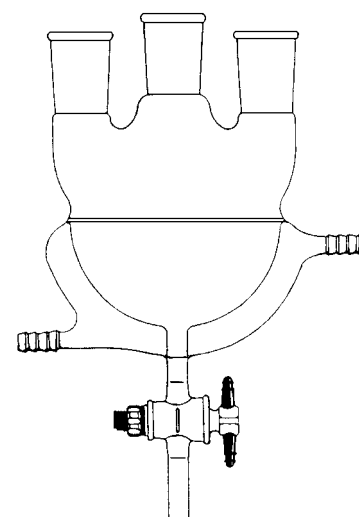

3223

3223 CONTINUED NEXT PAGE

3223 CONTINUED FROM PREVIOUS PAGE

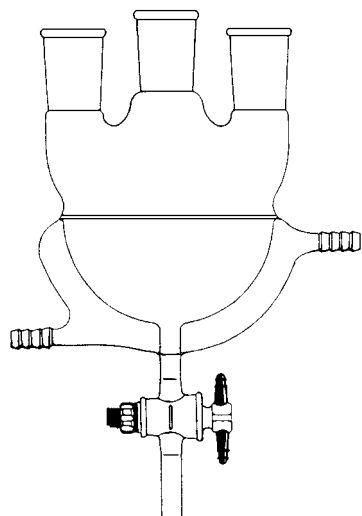

3223

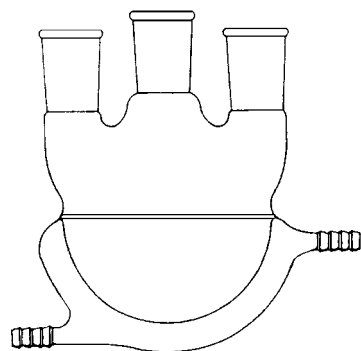

3224

3223 FLASK, ROUND BOTTOM, 3-NECK JACKETED WITH LOWER OUTLET

Standard taper outer joints on the center and vertical side necks. Bottom half of flask is jacketed with two hose connections. Available with either glass or Teflon 4mm bore stopcock.

GLASS STOPCOCK

Part Number	Center Neck	Side Necks	Capacity mL
3223-14	24/40	24/40	500
3223-15	29/42	24/40	500
3223-16	29/42	29/42	500
3223-17	24/40	24/40	1000
3223-18	29/42	24/40	1000
3223-19	29/42	29/42	1000
3223-20	24/40	24/40	2000
3223-21	29/42	24/40	2000
3223-22	29/42	29/42	2000
3223-23	29/42	24/40	3000
3223-24	29/42	29/42	3000
3223-25	45/50	24/40	3000
3223-26	45/50	29/42	3000

3224 FLASK, ROUND BOTTOM, 3-NECK, JACKETED

Standard taper outer joints on center and vertical side necks. Bottom half of flask is jacketed with two hose connections.

Part Number	Center Neck	Side Necks	Capacity mL
3224-01	24/40	24/40	500
3224-02	29/42	24/40	500
3224-03	29/42	29/42	500
3224-04	24/40	24/40	1000
3224-05	29/42	24/40	1000
3224-06	29/42	29/42	1000
3224-07	29/42	24/40	2000
3224-08	29/42	29/42	2000
3224-09	29/42	24/40	3000
3224-10	29/42	29/42	3000

3225 FLASK, ERLLENMEYER

Standard taper outer joint.

Part Number	Joint Size	Capacity mL
3225-01	24/40	250
3225-02	29/42	250
3225-03	24/40	500
3225-04	29/42	500
3225-05	24/40	1000
3225-06	29/42	1000
3225-07	24/40	2000
3225-08	29/42	2000



3225

3226 FLASK, ERLLENMEYER, FILTERING

Standard taper outer joint and side hose connection.

Part Number	Joint Size	Capacity mL
3226-01	24/40	250
3226-02	29/42	250
3226-03	24/40	500
3226-04	29/42	500
3226-05	24/40	1000
3226-06	29/42	1000
3226-07	24/40	2000
3226-08	29/42	2000



3226

3227 FLASK, ERLLENMEYER, WITH BAFFLES

Reinforced beaded top.

Part Number	Capacity mL
3227-01	250
3227-02	300
3227-03	500
3227-04	1000
3227-05	2000

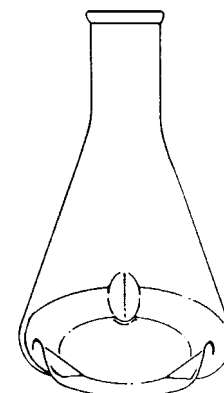

3227

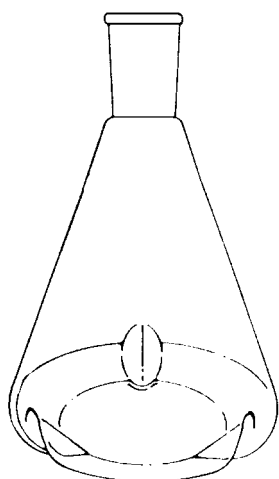

3228

3228 FLASK, ERLLENMEYER, WITH BAFFLES

Standard taper outer joint.

<u>Part Number</u>	<u>Joint Size</u>	<u>Capacity mL</u>
3228-01	24/40	250
3228-02	29/42	250
3228-03	24/40	500
3228-04	29/42	500
3228-05	24/40	1000
3228-06	29/42	1000
3228-07	24/40	2000
3228-08	29/42	2000



3229

3229 FLASK, DEWAR

Cylindrical flask, silvered and evacuated. Furnished with acrylic base.

<u>Part Number</u>	<u>Inside Diameter cm</u>	<u>Inside Height cm</u>	<u>Capacity mL</u>
3229-01	6	11.3	350
3229-02	6.8	19.5	665
3229-03	6.8	30.2	1000

FUNNELS

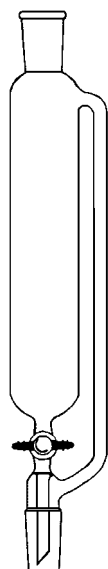

3300

3300 FUNNEL, ADDITION

Cylindrical funnel with pressure equalizing arm. Standard taper top outer and lower inner joints of the same size. Available with glass or Teflon stopcock.

TEFLON STOPCOCK

<u>Part Number</u>	<u>Joint Size</u>	<u>Stopcock Bore mm</u>	<u>Overall Height mm</u>	<u>Capacity mL</u>
3300-01	14/20	2	200	10
3300-02	14/20	2	200	25
3300-03	14/20	2	220	50
3300-04	14/20	2	220	60
3300-05	24/40	2	265	60
3300-06	24/40	2	325	125
3300-07	24/40	2	375	250
3300-08	24/40	4	435	500
3300-09	29/42	4	445	500
3300-10	24/40	4	520	1000
3300-11	29/42	4	525	1000
3300-12	24/40	6	530	2000
3300-13	29/42	6	535	2000

3300 CONTINUED NEXT PAGE

3300 CONTINUED
GLASS STOPCOCK

<u>Part Number</u>	<u>Joint Size</u>	<u>Stopcock Bore mm</u>	<u>Overall Height mm</u>	<u>Capacity mL</u>
3300-14	14/20	2	200	10
3300-15	14/20	2	200	25
3300-16	14/20	2	220	50
3300-17	14/20	2	220	60
3300-18	24/40	2	265	60
3300-19	24/40	2	325	125
3300-20	24/40	2	375	250
3300-21	24/40	4	435	500
3300-22	29/42	4	445	500
3300-23	24/40	4	520	1000
3300-24	29/42	4	525	1000
3300-25	24/40	6	530	2000
3300-26	29/42	6	535	2000

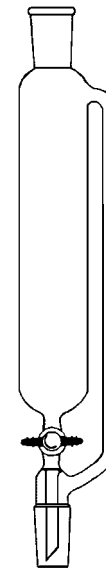
3300
3301 FUNNEL, ADDITION, WITH JACKET

Same as 3300, but with jacket for cooling with dry ice. Glass stopcock.

<u>Part Number</u>	<u>Joint Size</u>	<u>Stopcock Size</u>	<u>Capacity mL</u>
3301-01	14/20	2	25
3301-02	14/20	2	50
3301-03	24/40	2	60
3301-04	24/40	2	125
3301-05	24/40	2	250
3301-06	29/42	2	250
3301-07	24/40	4	500
3301-08	29/42	4	500

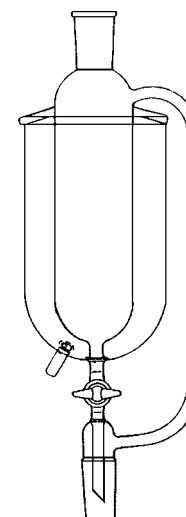
3301

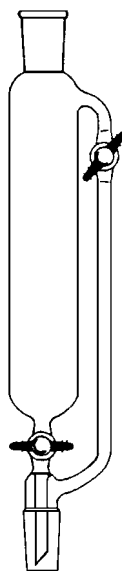

3302

3302 FUNNEL, ADDITION

Cylindrical funnel similar to 3300 with second stopcock in the pressure equalizing arm. Standard taper top outer and lower inner joints of the same size. Available with glass or Teflon stopcock.

TEFLON STOPCOCK

<u>Part Number</u>	<u>Joint Size</u>	<u>Stopcock Bore MM</u>	<u>Overall Height MM</u>	<u>Capacity mL</u>
3302-01	24/40	2	265	60
3302-02	24/40	2	325	125
3302-03	24/40	2	375	250
3302-04	24/40	4	435	500
3302-05	29/42	4	445	500
3302-06	24/40	4	520	1000
3302-07	29/42	4	525	1000
3302-08	24/40	6	530	2000
3302-09	29/42	6	535	2000

GLASS STOPCOCK

<u>Part Number</u>	<u>Joint Size</u>	<u>Stopcock Bore MM</u>	<u>Overall Height MM</u>	<u>Capacity mL</u>
3302-10	24/40	2	265	60
3302-11	24/40	2	325	125
3302-12	24/40	2	375	250
3302-13	24/40	4	435	500
3302-14	29/42	4	445	500
3302-15	24/40	4	520	1000
3302-16	29/42	4	525	1000
3302-17	24/40	6	530	2000
3302-18	29/42	6	535	2000

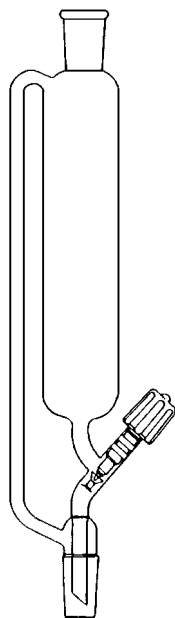

3303

3303 FUNNEL, ADDITION, THREADED VALVE

Cylindrical funnel with pressure equalizing arm. Standard taper top outer and lower inner joints of the same size. Teflon plug allows semi-needle valve action.

<u>Part Number</u>	<u>Joint Size</u>	<u>Valve Size</u>	<u>Overall Height MM</u>	<u>Capacity mL</u>
3303-01	14/20	2 mm	240	50
3303-02	14/20	2 mm	235	60
3303-03	24/40	2 mm	280	60
3303-04	24/40	4 mm	350	125
3303-05	24/40	4 mm	405	250
3303-06	24/40	4 mm	460	500
3303-07	29/42	4 mm	475	500
3303-08	24/40	4 mm	545	1000
3303-09	29/42	4 mm	550	1000

Call **1-800-880-7722** Toll Free

3304 FUNNEL, ADDITION, GRADUATED

Cylindrical funnel with pressure equalizing arm. Standard taper top outer and lower inner joints of the same size. Double scale of numbers. Available with glass or Teflon stopcock.

TEFLON STOPCOCK

Part Number	Joint Size	Stopcock Bore mm	Capacity mL	Subdivisions mL
3304-01	14/20	2	10	0.2
3304-02	24/40	2	10	0.2
3304-03	14/20	2	25	0.5
3304-04	24/40	2	25	0.5
3304-05	14/20	2	50	1.0
3304-06	29/42	2	50	1.0
3304-07	14/20	2	60	1.0
3304-08	24/40	2	60	1.0
3304-09	24/40	2	125	1.0
3304-10	29/42	2	125	1.0
3304-11	24/40	2	250	5.0
3304-12	29/42	2	250	5.0
3304-13	24/40	4	500	5.0
3304-14	29/26	4	500	5.0
3304-15	29/42	4	500	5.0
3304-16	24/40	4	1000	10.0
3304-17	29/42	4	1000	10.0
3304-18	24/40	6	2000	20.0
3304-19	29/42	6	2000	20.0

GLASS STOPCOCK

Part Number	Joint Size	Stopcock Bore mm	Capacity mL	Subdivisions mL
3304-20	14/20	2	10	0.2
3304-21	24/40	2	10	0.2
3304-22	14/20	2	25	0.5
3304-23	24/40	2	25	0.5
3304-24	14/20	2	50	1.0
3304-25	29/42	2	50	1.0
3304-26	14/20	2	60	1.0
3304-27	24/40	2	60	1.0
3304-28	24/40	2	125	1.0
3304-29	29/42	2	125	1.0

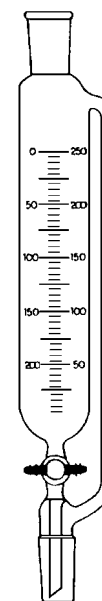
3304
3304 CONTINUED NEXT PAGE

3304 CONTINUED FROM PREVIOUS PAGE



3304

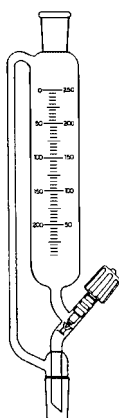

3305

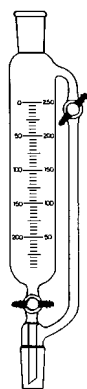

3306

3306 CONTINUED NEXT PAGE

GLASS STOPCOCK

Part Number	Joint Size	Stopcock Bore mm	Capacity mL	Subdivisions mL
3304-30	24/40	2	250	5.0
3304-31	29/26	2	250	5.0
3304-32	24/40	4	500	5.0
3304-33	29/26	4	500	5.0
3304-34	29/42	4	500	5.0
3304-35	24/40	4	1000	10.0
3304-36	29/42	4	1000	10.0
3304-37	24/40	6	2000	20.0
3304-38	29/42	6	2000	20.0

3305 FUNNEL, ADDITION, THREADED VALVE, GRADUATED

Same as 3303, but with double scale of numbers.

Part Number	Joint Size	Valve Size	Capacity mL	Subdivisions mL
3305-01	14/20	2 mm	50	1.0
3305-02	14/20	2 mm	60	1.0
3305-03	24/40	2 mm	60	1.0
3305-04	29/42	2 mm	60	1.0
3305-05	24/40	2 mm	125	1.0
3305-06	29/42	2 mm	125	1.0
3305-07	24/40	4 mm	250	5.0
3305-08	29/42	4 mm	250	5.0
3305-09	24/40	4 mm	500	5.0
3305-10	29/42	4 mm	500	5.0
3305-11	24/40	4 mm	1000	10.0
3305-12	29/42	4 mm	1000	10.0

3306 FUNNEL, ADDITION, GRADUATED

Same as 3302, but with double scale of numbers.

TEFLON STOPCOCK

Part Number	Joint Size	Stopcock Bore mm	Capacity mL	Subdivisions mL
3306-01	14/20	2	10	0.2
3306-02	24/40	2	10	0.2
3306-03	14/20	2	25	0.5
3306-04	24/40	2	25	0.5
3306-05	14/20	2	50	1.0
3306-06	29/26	2	50	1.0
3306-07	14/20	2	60	1.0
3306-08	24/40	2	60	1.0

3306 CONTINUED
TEFLON STOPCOCK

Part Number	Joint Size	Stopcock Bore mm	Capacity mL	Subdivisions mL
3306-09	24/40	2	125	1.0
3306-10	29/26	2	125	1.0
3306-11	24/40	2	250	5.0
3306-12	29/26	2	250	5.0
3306-13	24/40	4	500	5.0
3306-14	29/26	4	500	5.0
3306-15	29/42	4	500	5.0
3306-16	24/40	4	1000	10.0
3306-17	29/42	4	1000	10.0
3306-18	24/40	6	2000	20.0
3306-19	29/42	6	2000	20.0

GLASS STOPCOCK

Part Number	Joint Size	Stopcock Bore mm	Capacity mL	Subdivisions mL
3306-20	14/20	2	10	0.2
3306-21	24/40	2	10	0.2
3306-22	14/20	2	25	0.5
3306-23	24/40	2	25	0.5
3306-24	14/20	2	50	1.0
3306-25	24/40	2	50	1.0
3306-26	14/20	2	60	1.0
3306-27	24/40	2	60	1.0
3306-28	24/40	2	125	1.0
3306-29	29/26	2	125	1.0
3306-30	24/40	2	250	5.0
3306-31	29/26	2	250	5.0
3306-32	24/40	4	500	5.0
3306-33	29/26	4	500	5.0
3306-34	29/42	4	500	5.0
3306-35	24/40	4	1000	10.0
3306-36	29/42	4	1000	10.0
3306-37	24/40	6	2000	20.0
3306-38	29/42	6	2000	20.0

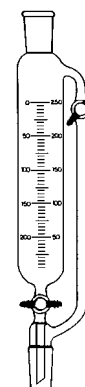
3306

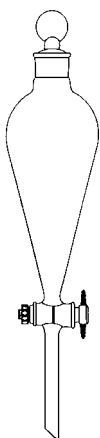

3307

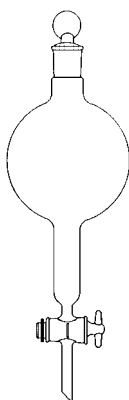

3308



3309

3307 FUNNEL, SEPARATORY, SQUIBB

Teflon stopcock. Includes stopper.

<u>Part Number</u>	<u>Stopcock Size</u>	<u>Stopper Size</u>	<u>Capacity mL</u>
3307-01	4	22	250
3307-02	4	27	500
3307-03	4	27	1000
3307-04	6	27	2000

3308 FUNNEL, SEPARATORY, GLOBE SHAPE

Globe shape provides secure grip. Available with glass or Teflon stopcock.

TEFLON STOPCOCK

<u>Part Number</u>	<u>Stopcock Size</u>	<u>Stopper Size</u>	<u>Capacity mL</u>
3308-01	8	45/50	3000
3308-02	8	45/50	5000
3308-03	10	55/50	12000

GLASS STOPCOCK

<u>Part Number</u>	<u>Stopcock Size</u>	<u>Stopper Size</u>	<u>Capacity mL</u>
3308-04	8	45/50	3000
3308-05	8	45/50	5000
3308-06	10	55/50	12000

3309 FUNNEL, SEPARATORY

Cylindrical funnel with standard taper stopper top. Available with glass or Teflon stopcock.

TEFLON STOPCOCK

<u>Part Number</u>	<u>Stopcock Size</u>	<u>Stopper Size</u>	<u>Overall Height mm</u>	<u>Capacity mL</u>
3309-01	2	16	235	60
3309-02	2	22	290	125
3309-03	2	22	330	250
3309-04	4	27	405	500
3309-05	4	27	485	1000

GLASS STOPCOCK

<u>Part Number</u>	<u>Stopcock Size</u>	<u>Stopper Size</u>	<u>Overall Height mm</u>	<u>Capacity mL</u>
3309-06	2	16	235	60
3309-07	2	22	290	125
3309-08	2	22	330	250
3309-09	4	27	405	500
3309-10	4	27	485	1000

3310 FUNNEL, SEPARATORY

Same as 3309, but with double scale of numbers.

TEFLON STOPCOCK

Part Number	Stopcock Size	Stopper Size	Capacity mL	Subdivisions mL
3310-01	2	16	60	1.0
3310-02	2	22	125	1.0
3310-03	2	22	250	5.0
3310-04	4	27	500	5.0
3310-05	4	27	1000	10.0

GLASS STOPCOCK

Part Number	Stopcock Size	Stopper Size	Capacity mL	Subdivisions mL
3310-06	2	16	60	1.0
3310-07	2	22	125	1.0
3310-08	2	22	250	5.0
3310-09	4	27	500	5.0
3310-10	4	27	1000	10.0

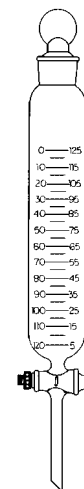
3310
3311 FUNNEL, SEPARATORY, GRADUATED

Cylindrical funnel with standard taper top outer joint and lower inner joint. Graduated with double scale of numbers. Teflon stopcock.

Part Number	Joint Size	Stopcock Size	Capacity mL	Subdivisions mL
3311-01	14/20	2	10	0.2
3311-02	14/20	2	25	0.5
3311-03	14/20	2	50	1.0
3311-04	14/20	2	60	1.0
3311-05	24/40	2	60	1.0
3311-06	24/40	2	125	1.0
3311-07	24/40	2	250	5.0
3311-08	24/40	4	500	5.0
3311-09	29/42	4	500	5.0
3311-10	24/40	4	1000	10.0
3311-11	29/42	4	1000	10.0

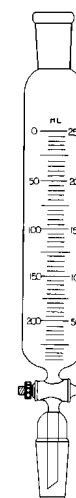
3311



3400

3400 GAS SAMPLING TUBE

For the collection and storage of gas samples. Available with glass or Teflon stopcocks.

TEFLON STOPCOCK

<u>Part Number</u>	<u>Stopcock Bore mm</u>	<u>Approx. Overall Length mm</u>	<u>Capacity mL</u>
3400-01	2	290	125
3400-02	4	320	250
3400-03	4	345	500

GLASS STOPCOCK

<u>Part Number</u>	<u>Stopcock Bore mm</u>	<u>Approx. Overall Length mm</u>	<u>Capacity mL</u>
3400-04	2	290	125
3400-05	4	320	250
3400-06	4	345	500

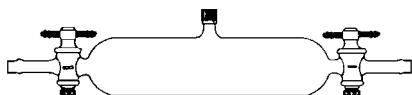

3401

3401 GAS SAMPLING TUBE, WITH SAMPLING PORT

Same as 3400, but with the addition of a syringe sampling port. Available with glass or Teflon stopcocks.

TEFLON STOPCOCK

<u>Part Number</u>	<u>Stopcock Bore mm</u>	<u>Approx. Overall Length mm</u>	<u>Capacity mL</u>
3401-01	2	290	125
3401-02	4	320	250
3401-03	4	345	500

GLASS STOPCOCK

<u>Part Number</u>	<u>Stopcock Bore mm</u>	<u>Approx. Overall Length mm</u>	<u>Capacity mL</u>
3401-04	2	290	125
3401-05	4	320	250
3401-06	4	345	500

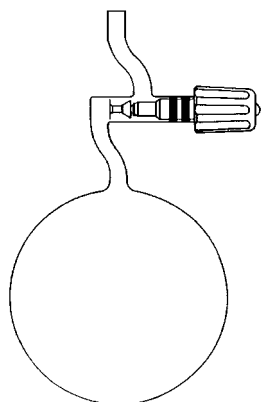

3402

3402 GAS BALLOON

Gas balloon with 0-4mm high vacuum valve.

<u>Part Number</u>	<u>Capacity mL</u>
3402-01	100
3402-02	250
3402-03	500
3402-04	1000

3403 GAS SAMPLING TUBE

For the collection and storage of gas samples. 0-4mm Teflon valves at both ends.

<u>Part Number</u>	<u>Stopcock Bore mm</u>	<u>Approx. Overall Length mm</u>	<u>Capacity mL</u>
3403-01	2	325	125
3403-02	4	340	250
3403-03	4	355	500

3500 IMPINGER, GREENBURG-SMITH 45/50

A high velocity impinger for use in the determination of dust concentration in air or other non-condensable gases. Standard taper 45/50 joint on bottle and stopper. Approx. 500mL capacity.

Complete Impinger with Plain Tip:

<u>Part Number</u>	<u>Joint Size</u>
3500-01	Plain
3500-02	18/9
3500-03	25/15

Complete Impinger with Plate:

<u>Part Number</u>	<u>Joint Size</u>
3500-04	Plain
3500-05	18/9
3500-06	25/15

Stopper only with Plain Tip:

<u>Part Number</u>	<u>Joint Size</u>
3500-07	Plain
3500-08	18/9
3500-09	28/15

Stopper only with Plate:

<u>Part Number</u>	<u>Joint Size</u>
3500-10	Plain
3500-11	18/9
3500-12	28/15

Bottle only:

<u>Part Number</u>	<u>Joint Size</u>
3500-13	45/50

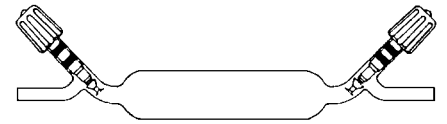

3403

IMPINGERS

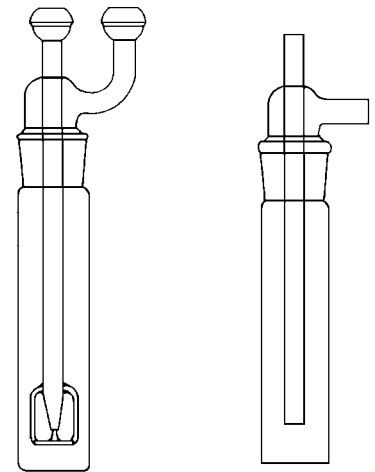

3500

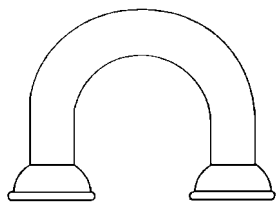

3501

3501 IMPINGER CONNECTOR

U-shaped adapter with spherical joints at both ends.

<u>Part Number</u>	<u>Joint Size</u>	<u>Center to Center mm</u>
3501-01	18/9	75
3501-02	28/15	75

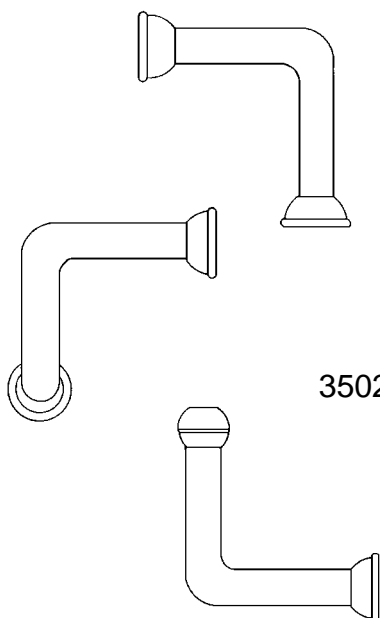

3502

3502 ADAPTER, 90°

90° connecting adapters.

<u>Part Number</u>	<u>Joint Size</u>	<u>Description</u>
3502-01	18/9	90° Probe Connector
3502-02	28/15	90° Probe Connector
3502-03	18/9	Double "L" Connector
3502-04	28/15	Double "L" Connector
3502-05	18/9	Cyclone Bypass
3502-06	28/15	Cyclone Bypass

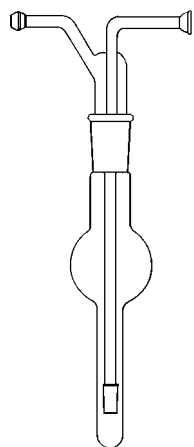

3503

3503 BUBBLER, SMOG

Standard taper 24/40 joint. Fritted gas dispersion tube.

<u>Part Number</u>	<u>Description</u>
3503-01	Bubbler, Complete
3503-02	Stopper Only, 24/40, 12/5
3503-03	Bottle Only, 24/40



3504

3504 GAS DISPERSION TUBE, FRITTED

<u>Part Number</u>	<u>Porosity</u>
3504-01	Fine
3504-02	Medium
3504-03	Coarse
3504-04	X-Coarse

HEMISPHERICAL-STYLE MANTLES

Glas-Col hemispherical-style mantles let you easily view flask contents. This Series O mantle is a hemispherical style, meaning it covers only the bottom half of the flask. This allows full view of contents. The mantle accommodates single- and multi-neck flasks. It should be used with the Series O supports below and on the following page.

Catalog Number <u>115 volt</u>	Catalog Number <u>230 volt</u>	Flask Capacity <u>mL</u>	Flask Dia. <u>mm</u>	<u>Watts</u>
100A 0394	*	50	48	60
100A 0396	*	100	60	80
100A 0398	*	125	70	80
100A 0400	100A 0401	200	76	100
100A 0402	100A 0403	250	83	180
100A 0404	100A 0405	300	86	180
100A 0406	100A 0407	500	101	270
100A 0408	100A 0409	1000	137	380
100A 0410	100A 0411	2000	170	500
100A 0412	100A 0413	3000	183	500
100A 0414	100A 0415	5000	220	600
100A 0416	100A 0417	12000	293	2@650

Sizes marked with an asterisk (*) are not available in 230 volt.

SPHERICAL MANTLES

Glas-Col spherical mantles can help you improve safety and efficiency. This spherical mantle covers both top and bottom of 1-, 2-, or 3-neck spherical flasks for improved safety and efficiency. The circumferential zipper holds the halves snugly together to prevent heat loss, and the side split in top allows removal without disturbing the flask.

Catalog Number <u>115 volt</u>	Catalog Number <u>230 volt</u>	Flask Capacity <u>mL</u>	Distribution of Wattage	
			<u>lower half</u>	<u>upper half</u>
100A 0943	*	50	60	None
100A 0963	*	100	80	None
100A 0983	*	125	80	None
100A 01003	100A 01013	200	100	None
100A 01023	100A 01033	250	180	None
100A 01043	100A 01053	300	180	None
100A 01063	100A 01073	500	270	None
100A 01083	100A 01093	1000	380	140
100A 01103	100A 01113	2000	500	200
100A 01123	100A 01133	3000	500	200
100A 01143	100A 01153	5000	600	300
100A 01163	100A 01173	12000	2@650	590

Sizes marked with an asterisk (*) are not available in 230 volt.



Hemispherical-Style Mantles

Specifications

Certification: All 115 volt items are CSA certified.

Electrical: Separable 4-ft, 2-wire cord and locking connector.



Spherical Mantles

Specifications

Certification: All 115 volt items are CSA certified.

Electrical: Separable 4-ft, 2-wire cord and locking connector.



Resin Reaction Flask Mantle

Specifications

Certification: All 115 volt items are CSA certified.

Electrical: Separable 4-ft, 2-wire cord and locking connector.



Griffin Beaker Mantle

Specifications

Certification: All 115 volt items are CSA certified.

Electrical: Separable 4-ft, 2-wire cord and locking connector.

RESIN REACTION FLASK MANTLE

Glas-Col resin reaction flask mantles prevent scorching. This mantle's even heat distribution prevents scorching of clear resinous materials. Its one-circuit heat input simplifies temperature control.

For Corning 6947 or Kimble 63700 Flask					
Catalog Number <u>115 volt</u>	Catalog Number <u>230 volt</u>	Flask Capacity <u>mL</u>	Flask Dia. <u>in.</u>	Mantle Depth <u>in.</u>	<u>Watts</u>
100A 0570	100A 0571	500	3 3/4	4 1/2	270
100A 0572	100A 0573	1000	4 1/4	5 1/4	335
100A 0576	100A 0577	2000	5 1/2	6	470
100A 0578	100A 0579	3000	5 1/2	9	550
100A 0580	100A 0581	4000	5 1/2	11	750

GRIFFIN BEAKER MANTLE

Glas-Col flexible mantles provide efficient heat for Griffin beakers. A resilient and pliable interior cradles fragile beakers. Even small liquid volumes may be heated in this mantle because its heat is concentrated at the bottom.

Catalog Number <u>115 volt</u>	Catalog Number <u>230 volt</u>	Beaker Capacity <u>mL</u>	Beaker Dia. <u>in.</u>	Mantle Depth <u>in.</u>	<u>Watts</u>
100A 0600	*	50	1 5/8	1 5/8	40
100A 0602	100A 0603	100	2	2	100
100A 0604	100A 0605	150	2 1/4	2 3/8	100
100A 0606	100A 0607	250	2 11/16	2 1/2	140
100A 0608	100A 0609	400	3	3 1/4	240
100A 0610	100A 0611	600	3 9/16	3 3/4	325
100A 0612	100A 0613	800	3 7/8	4 1/4	350
100A 0614	100A 0615	1000	4 1/4	4 1/2	430
100A 0616	100A 0617	2000	5 1/8	6	550
100A 0618	100A 0619	3000	5 3/4	6 1/2	630
100A 0620	100A 0621	4000	6 3/8	8	710

Sizes marked with an asterisk (*) are not available in 230 volt.

MINITROL

Glas-Col Minitrol allows manual heat control. The operator manually adjusts the Minitrol, which has a percentage-timer design and no sensing element. It regulates mantles, tapes, and cords, as well as small furnaces, ovens, hot plates, dies, and other applications requiring stepless control. Minitrol may also be used on any non-inductive loads to its rated capacity. It proportions the operating voltage to the load from 5 1/2% to 100% of the time according to the preset dial position. When turned off, it effects a positive break. For very small loads, smaller fuses may be used. PL3122 Minitwin handles two separate circuits. A pilot light is connected across the output side of the control, indicating power to load. With the desired temperature determined on the initial run, a simple dial setting controls repeat operation.

Catalog Number	Number Circuits	Volts	Amps Per Circuit	Wattage Capacity	Case Dimensions (inches)
104A PL312	1	120	12	1440	2 1/2 x 4 1/4 x 2
104A PL3122	2	120	7.5	900 per circuit	5 x 4 1/4 x 2
104A PL324	1	240	10	2400	2 1/2 x 4 1/4 x 2

Catalog number PL3122 Glas-Col Minitwin has two circuits for regulating two heating operations at once.



Minitrol

Specifications

Certification: CSA certified.

Electrical: Pilot light, fuse protection, 3 wire load receptacle, and 3-wire line cord with molded plug.

Case Construction: Anodized aluminum with no-mar rubber feet.



Minitwin

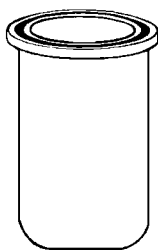

3600

3600 REACTION KETTLE, BODY

Reaction kettle has a flat flange with o-ring groove.

Part Number	Capacity mL
3600-01	500
3600-02	1000
3600-03	2000
3600-04	3000
3600-05	4000

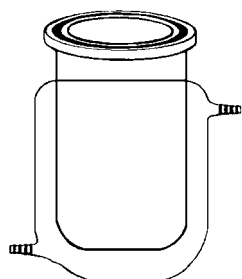

3601

3601 REACTION KETTLE, BODY, JACKETED

Same as 3600, but jacketed.

Part Number	Capacity mL
3601-01	500
3601-02	1000
3601-03	2000
3601-04	3000
3601-05	4000

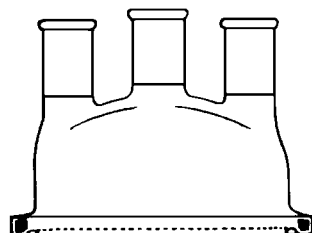

3602

3602 REACTION KETTLE, COVER, 3-NECK

Standard taper center and side necks are 180° apart. O-ring groove. Fits 500 and 1000 mL kettle bodies.

Part Number	Joint Center Neck	Joints Side Necks
3602-01	24/40	24/40
3602-02	29/42	24/40
3602-03	29/42	29/42

Fits 2000, 3000 and 4000 mL kettle bodies.

3602-04	24/40	24/40
3602-05	29/42	24/40
3602-06	29/42	29/42

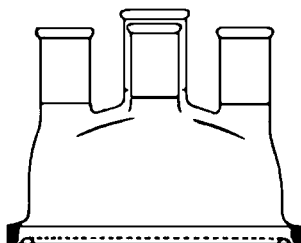

3603

3603 REACTION KETTLE, COVER, 4-NECK

Standard taper center and side necks. O-ring groove. Fits 500 and 1000 mL kettle bodies.

Part Number	Joint Center Neck	Joints Side Necks
3603-01	24/40	24/40
3603-02	29/42	24/40
3603-03	29/42	29/42

Fits 2000, 3000 and 4000 mL kettle bodies.

3603-04	24/40	24/40
3603-05	29/42	24/40
3603-06	29/42	29/42

3604 REACTION KETTLE, COVER, 4-NECK

Standard taper center and side necks. Fourth joint is 10/30 for use with thermometer. O-ring groove.
Fits 500 and 1000 mL kettle bodies.

Part Number	Joint Center Neck	Joints Side Necks
3604-01	24/40	24/40
3604-02	29/42	24/40
3604-03	29/42	29/42

Fits 2000, 3000 and 4000 mL kettle bodies.

3604-04	24/40	24/40
3604-05	29/42	24/40
3604-06	29/42	29/42

3605 REACTION KETTLE, BODY, WITH BAFFLES

Reaction kettle with indentations for improved stirring. O-ring groove.

Part Number	Capacity mL
3605-01	500
3605-02	1000
3605-03	2000
3605-04	3000
3605-05	4000

3606 REACTION KETTLE, BODY, WITH BAFFLES, JACKETED

Same as 3605, but jacketed.

Part Number	Capacity mL
3606-01	500
3606-02	1000
3606-03	2000
3606-04	3000
3606-05	4000

3607 CLAMP

Clamp for use with reaction kettles and covers.

Part Number	Size
3607-01	80mm
3607-02	4 1/2"
3607-03	5 1/2"

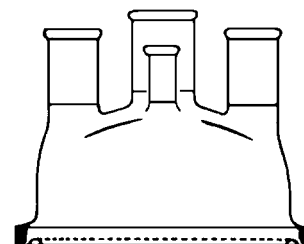

3604

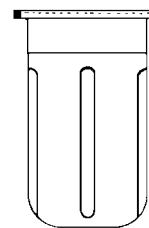

3605

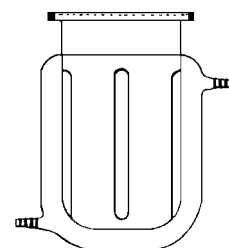

3606



3607

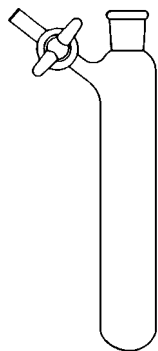

3608

3608 REACTION TUBE

For storage or simple reactions. Standard taper outer joint. 2mm glass stop-cock.

<u>Part Number</u>	<u>Capacity mL</u>	<u>Joint Size</u>
3608-01	25	14/20
3608-02	50	14/20
3608-03	100	14/20
3608-04	100	24/40
3608-05	250	24/40

REACTORS, PILOT PLANT

3700 PILOT PLANT REACTORS

Pilot plant reactors are customized to your specific needs. Please call with your requirements and we will be pleased to help design and provide a quote for your pilot plant system.



3700

3800 STIRRERS

All types of stirrers and stirring accessories are available. Please call with your requirements.

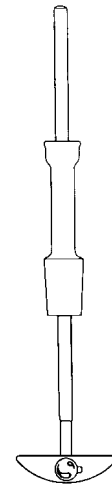

3800

3900 STOPPER, CAP STYLE

For use with standard taper inner joints.

Part Number	Joint Size
3900-01	14/20
3900-02	24/40
3900-03	29/42

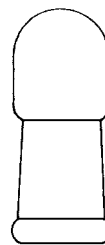

3900

3901 STOPPER, CYLINDRICAL

For use with standard taper outer joints.

Part Number	Joint Size
3901-01	24/40
3901-02	29/42
3901-03	34/45
3901-04	45/50
3901-05	55/50

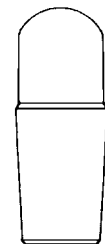

3901

3902 STOPPER, SPHERICAL, PENNYHEAD

For use with spherical socket joint.

Part Number	Spherical Size
3902-01	12
3902-02	18
3902-03	28
3902-04	35



3902

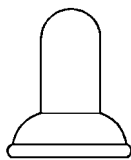

3903

3903 STOPPER, CAP STYLE, SPHERICAL

For use with spherical ball joint.

<u>Part Number</u>	<u>Spherical Size</u>
3903-01	12
3903-02	18
3903-03	28
3903-04	35

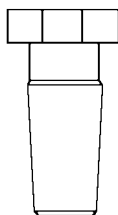

3904

3904 STOPPER, HEX HEAD

For use with standard taper outer joints.

<u>Part Number</u>	<u>Joint Size</u>
3904-01	14/20
3904-02	24/40
3904-03	29/42
3904-04	45/50



3905

3905 STOPPER, FLASK LENGTH, PENNYHEAD

<u>Part Number</u>	<u>Joint Size</u>
3905-01	9
3905-02	13
3905-03	16
3905-04	19
3905-05	22
3905-06	27
3905-07	32
3905-08	38

4000 VACUUM MANIFOLDS

Vacuum manifolds are customized to your specific needs. Manifolds shown are representative only. Please call with your requirements and we will be pleased to provide you with a quote.

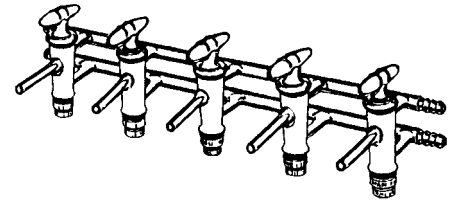
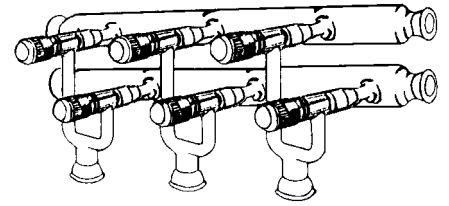

4000

VACUUM TRAPS

4100 VACUUM TRAP

For use in the removal of undesirable vapors in the vacuum system.

<u>Part Number</u>	<u>Body O.D. x Length (mm)</u>	<u>O.D. of Side and Inner Tubes (mm)</u>
4100-01	25 x 200	10
4100-02	35 x 250	16
4100-03	45 x 350	25

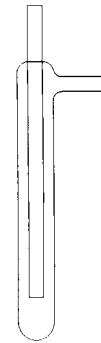

4100

4101 VACUUM TRAP, 90°

Same as 4100, but with top inlet tube bent at 90° angle.

<u>Part Number</u>	<u>Body O.D. x Length (mm)</u>	<u>O.D. of Side and Inner Tubes (mm)</u>
4101-01	25 x 200	10
4101-02	35 x 250	16
4101-03	45 x 350	25

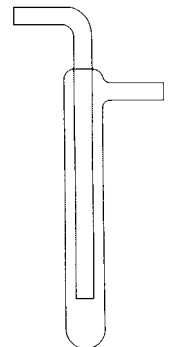

4101

4102 VACUUM TRAP, WITH JOINT

Two part vacuum trap with standard taper joints to facilitate cleaning.

<u>Part Number</u>	<u>Body O.D. x Length (mm)</u>	<u>O.D. of Side and Inner Tube (mm)</u>	<u>Joint Size</u>
4102-01	32 x 200	10	29/42
4102-02	38 x 225	13	34/45
4102-03	45 x 250	16	40/50

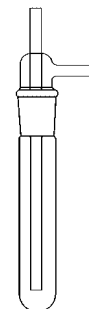

4102

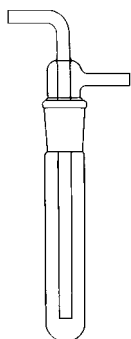

4103

4103 VACUUM TRAP, 90°, WITH JOINT

Same as 4102, but with top inlet tube bent at 90° angle.

<u>Part Number</u>	<u>Body O.D. x Length (mm)</u>	<u>O.D. of Side and Inner Tube (mm)</u>	<u>Joint Size</u>
4103-01	32 x 200	10	29/42
4103-02	38 x 225	13	34/45
4103-03	45 x 250	16	40/50

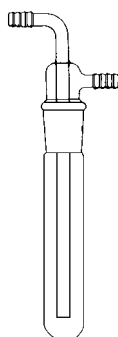

4104

4104 VACUUM TRAP, 90°, WITH HOSE CONNECTIONS

Same as 4103, but with hose connections on inlet and outlet tubes.

<u>Part Number</u>	<u>Body O.D. x Length (mm)</u>	<u>O.D. of Side and Inner Tube (mm)</u>	<u>Joint Size</u>
4104-01	32 x 200	10	29/42
4104-02	38 x 225	13	34/45
4104-03	45 x 250	16	40/50

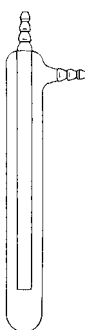

4105

4105 VACUUM TRAP, WITH HOSE CONNECTIONS

Similar to 4100, but with hose connections on inlet and outlet tubes. Offered in 48mm OD x 350mm long. Inner tube is 19mm OD. 10mm hose connections.

<u>Part Number</u>
4105-01

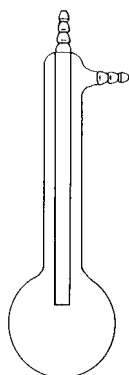

4106

4106 VACUUM TRAP, BULB, WITH HOSE CONNECTIONS

Similar to 4105, but with bulb reservoir. 48mm OD, 19mm inner tube. 10mm hose connections.

<u>Part Number</u>	<u>Reservoir Capacity</u>
4106-01	250mL
4106-02	500mL
4106-03	1000mL
4106-04	2000mL

